

# Equipment Preselection How, Why & Lessons Learned

**PNWS AWWA Conference**

May 3, 2024

# Acknowledgements



**King County**



# Key Takeaways



**When & Why to Preselect**

**Planning for Preselection**

**Strategies to Achieve a  
Good Outcome**

# Agenda



**Preselection 101**

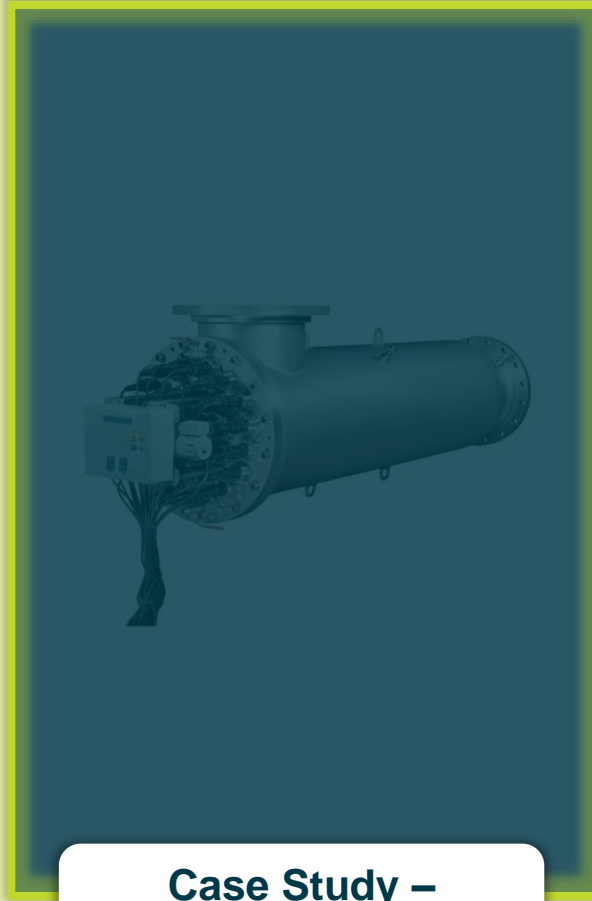

**Case Study –  
Brightwater UV**

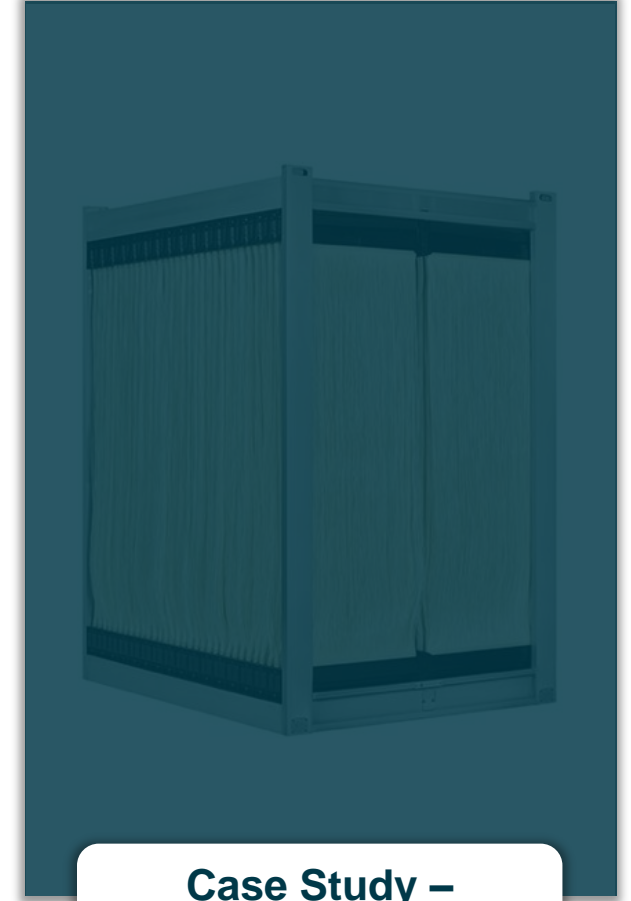

**Case Study –  
Ventura MBR/UV**



# Agenda



**Preselection 101**

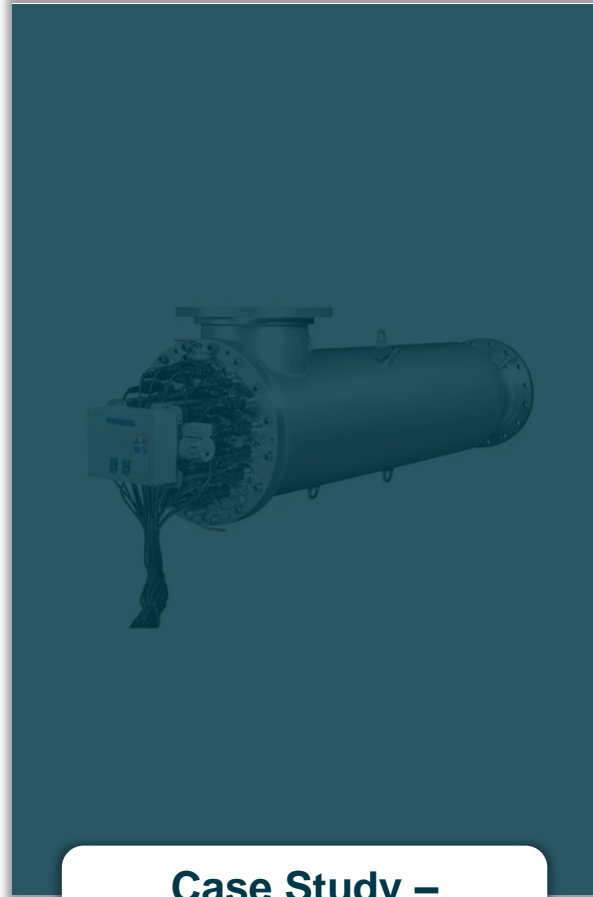

**Case Study –  
Brightwater UV**

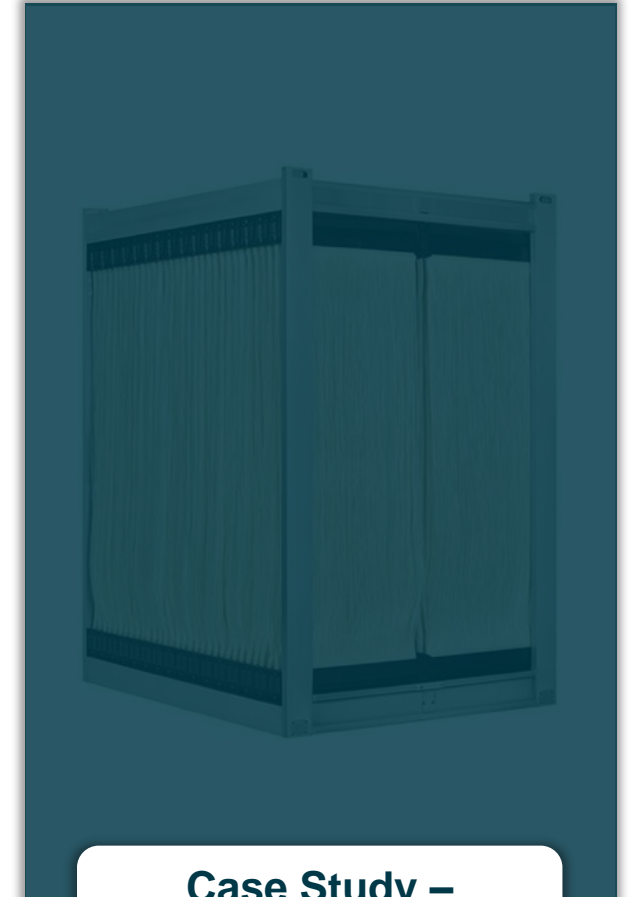

**Case Study –  
Ventura MBR/UV**



# What is equipment preselection?

## Typical Project

Complete  
Design

Contractor  
Bidding

Shop  
Drawings

Complete  
Construction

# What is equipment preselection?

## Preselection

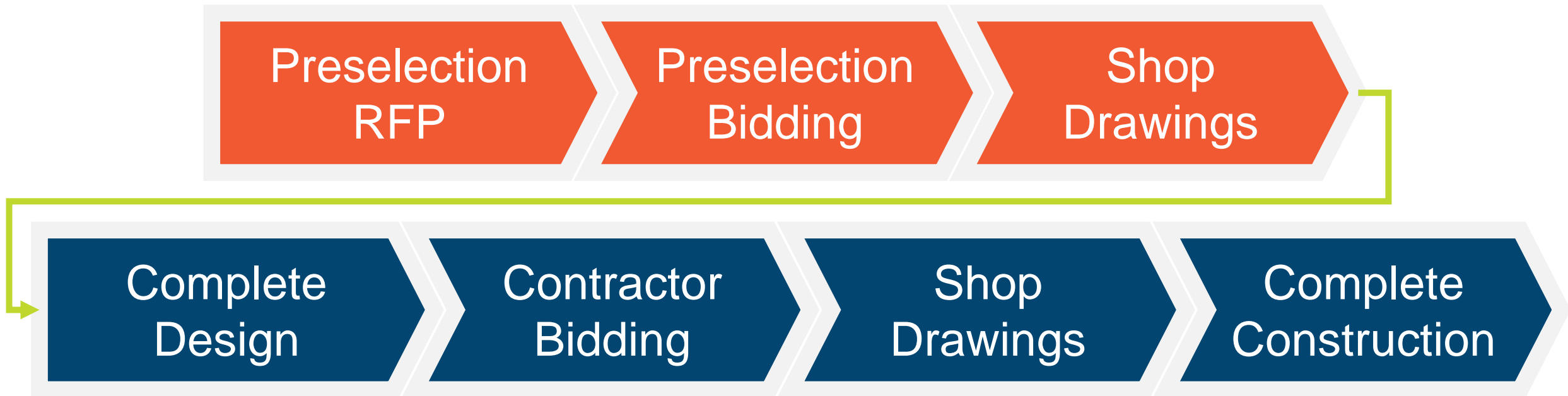

# When should we preselect equipment?

When product options are interchangeable...





# When should we preselect equipment?

When product options aren't interchangeable...



# Why should we preselect equipment?

Consequences of designing around non-interchangeable equipment



**Waste**



**Conflict**

# Why should we preselect equipment?

“Best value” product is subjective and isn’t always lowest cost

## The Seattle Times

Local	National/International
Business	Real Estate/Travel
Sports	Opinion
Entertainment	<b>\$164/year subscription</b>
Lifestyle	<b>400k subscribers</b>

## The New York Times

Local	National/International
Business	Real Estate/Travel
Sports	Opinion
Entertainment	<b>\$520/year subscription</b>
Lifestyle	<b>9.3M subscribers</b>

# Why should we preselect equipment?

“Best value”  
could include...

Cost

O&M

Reliability

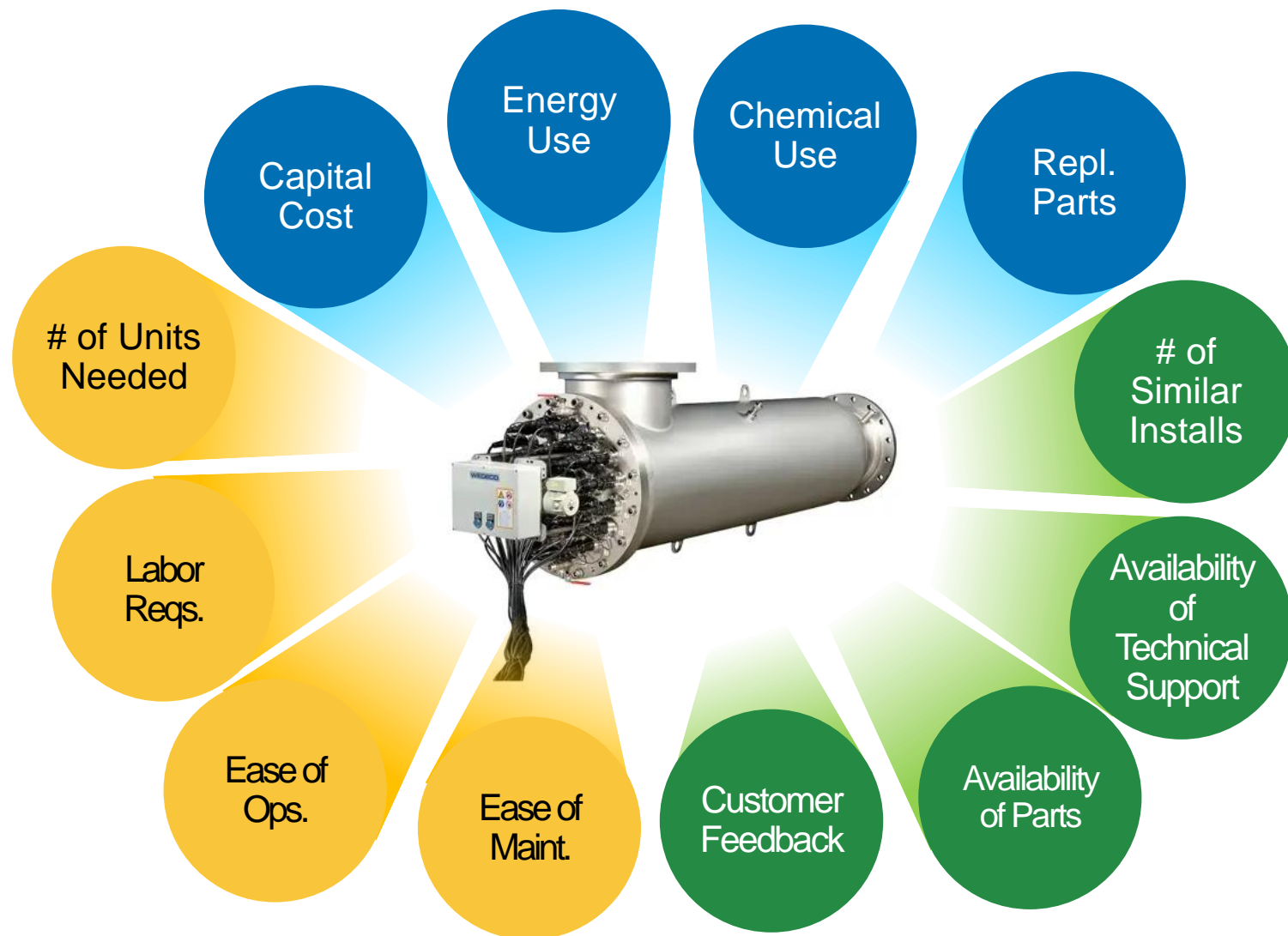

# Why should we preselect equipment?

Potential consequences of lowest cost selection



# Equipment to Consider for Preselection

- Unique layout
- O&M differences
- Life cycle cost



# Steps of the Preselection Process

Equipment  
Specification

Request for  
Proposal

Evaluate  
Proposals

Selection and  
Contract

# Roles & Responsibilities of Those Involved



Consultant Engineers



Owner  
Project  
Engineer



Owner  
Project Manager



Owner Operations



Owner Procurement



Owner Legal

**Evaluation Team**



# Assignment to the General Contractor

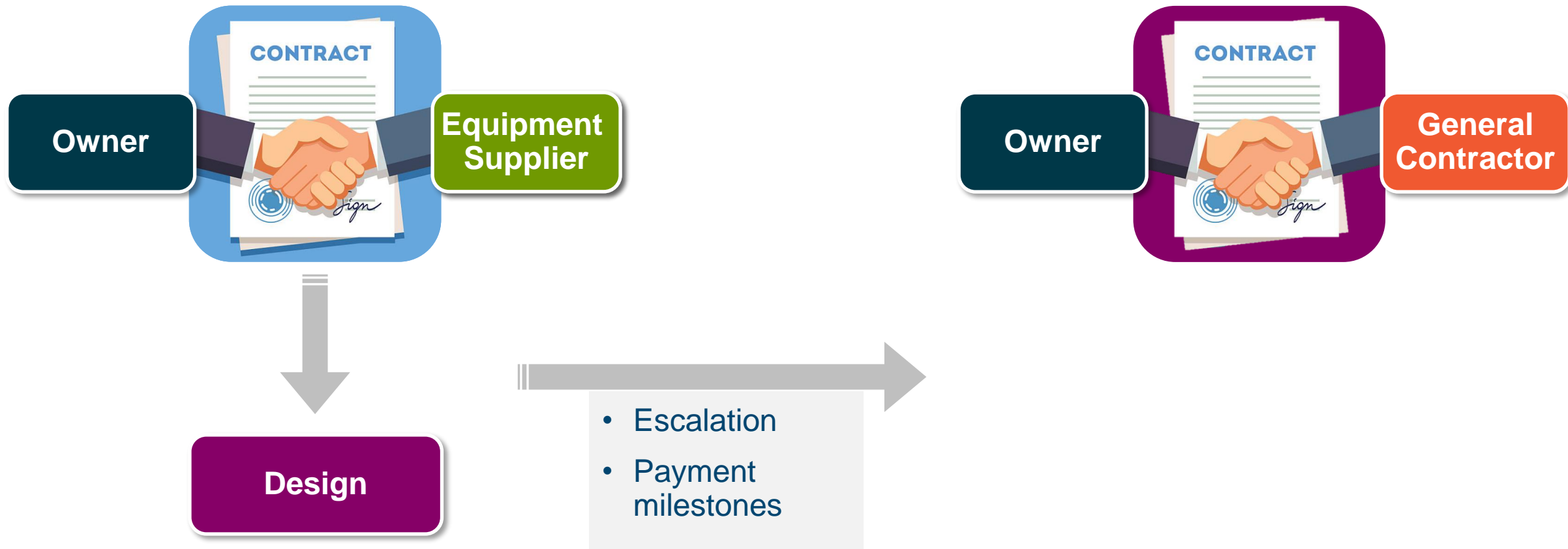

# Assignment to the General Contractor

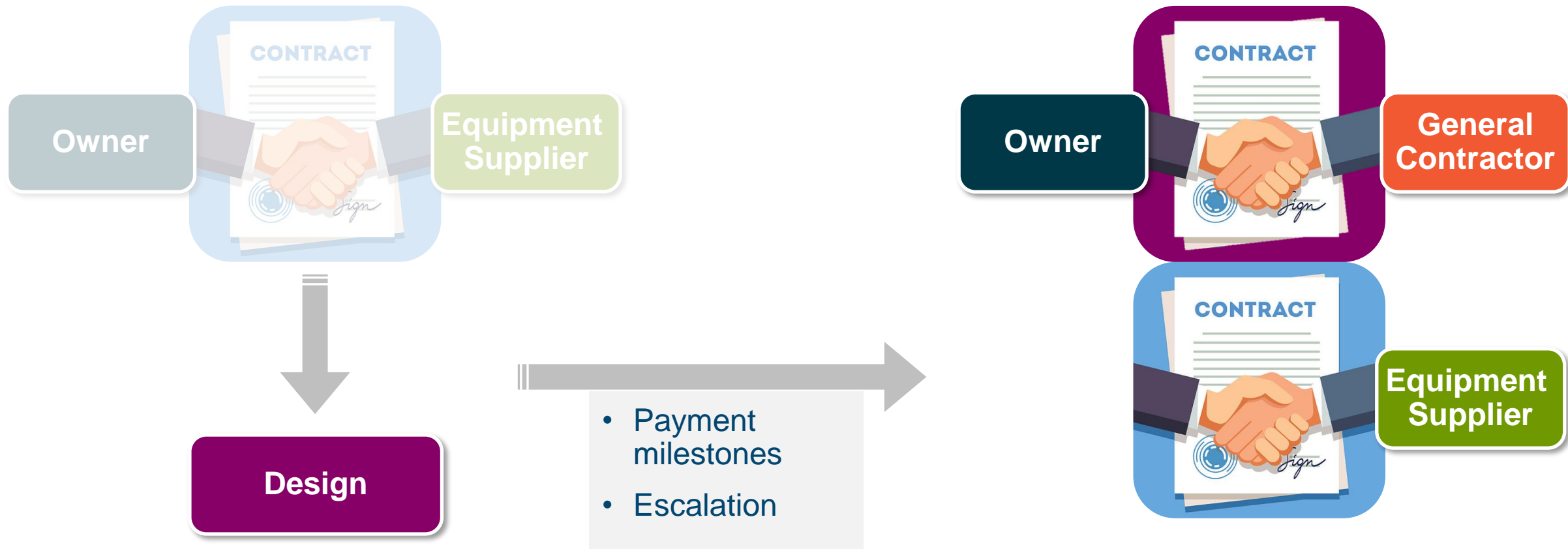

# Other Procurement Methods Comparison

Method	Preferred Equipment	Competitive	Schedule
<b>Bid Advertisement</b>	✗	✓	✓
<b>Sole Source</b>	✓	✗	✓
<b>Prepurchase-Owner Furnished</b>	✓	✓	✗
<b>Base Bid, Alternative Bid</b>	✓	✓	✗

# Agenda



**Preselection 101**

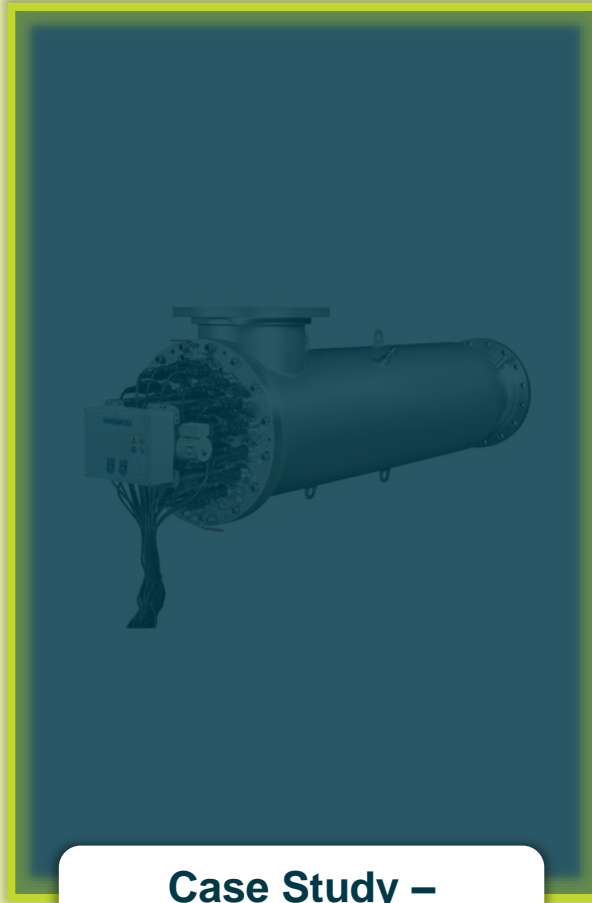

**Case Study –  
Brightwater UV**

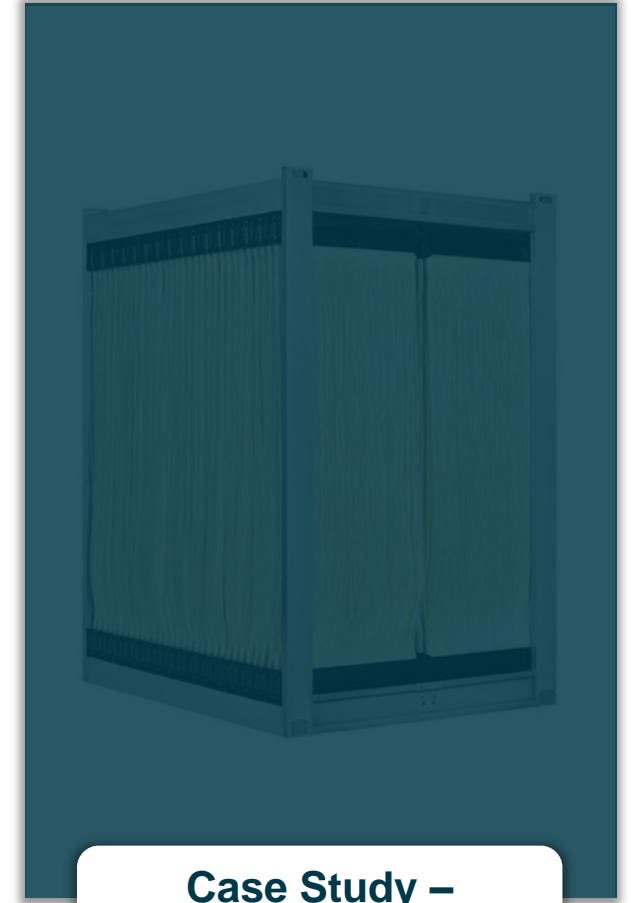

**Case Study –  
Ventura MBR/UV**



# Brightwater Treatment Plant



# Project Objectives

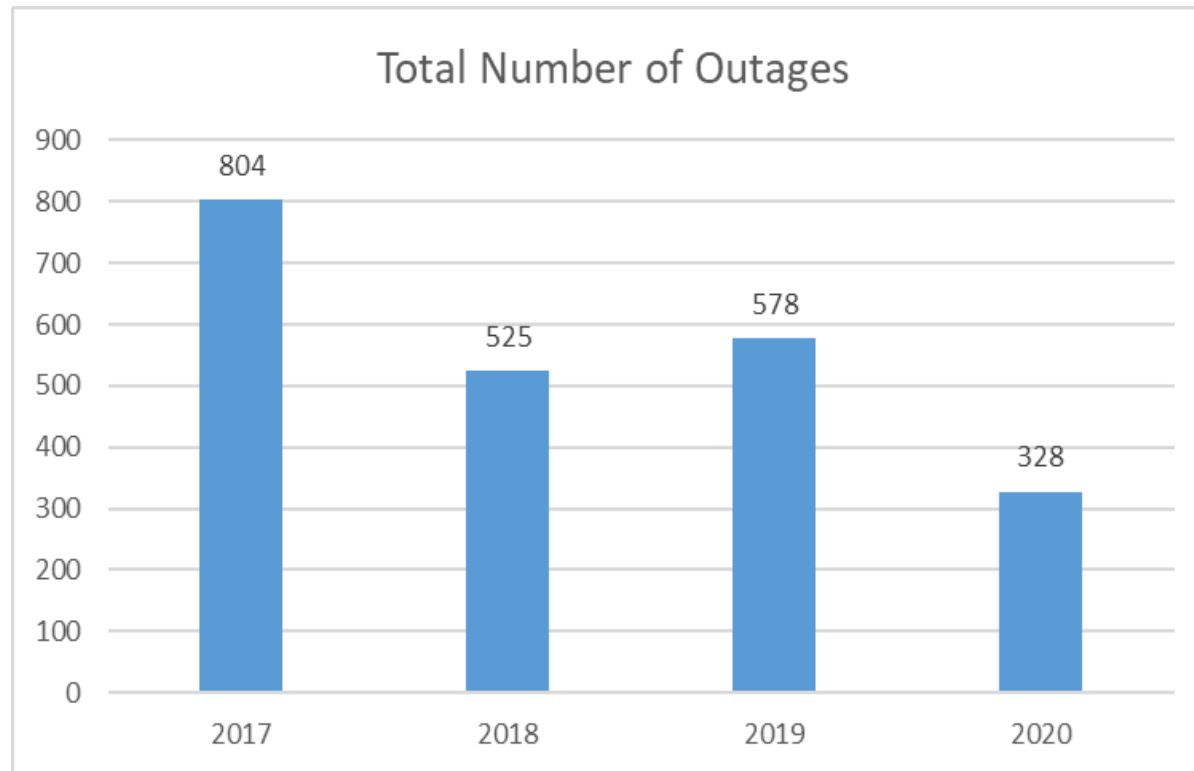

- ✓ Improve reliability
- ✓ Simplify operation
- ✓ Meet O&M staff needs

 **Disinfection System Improvements**

# Process Flow Diagram

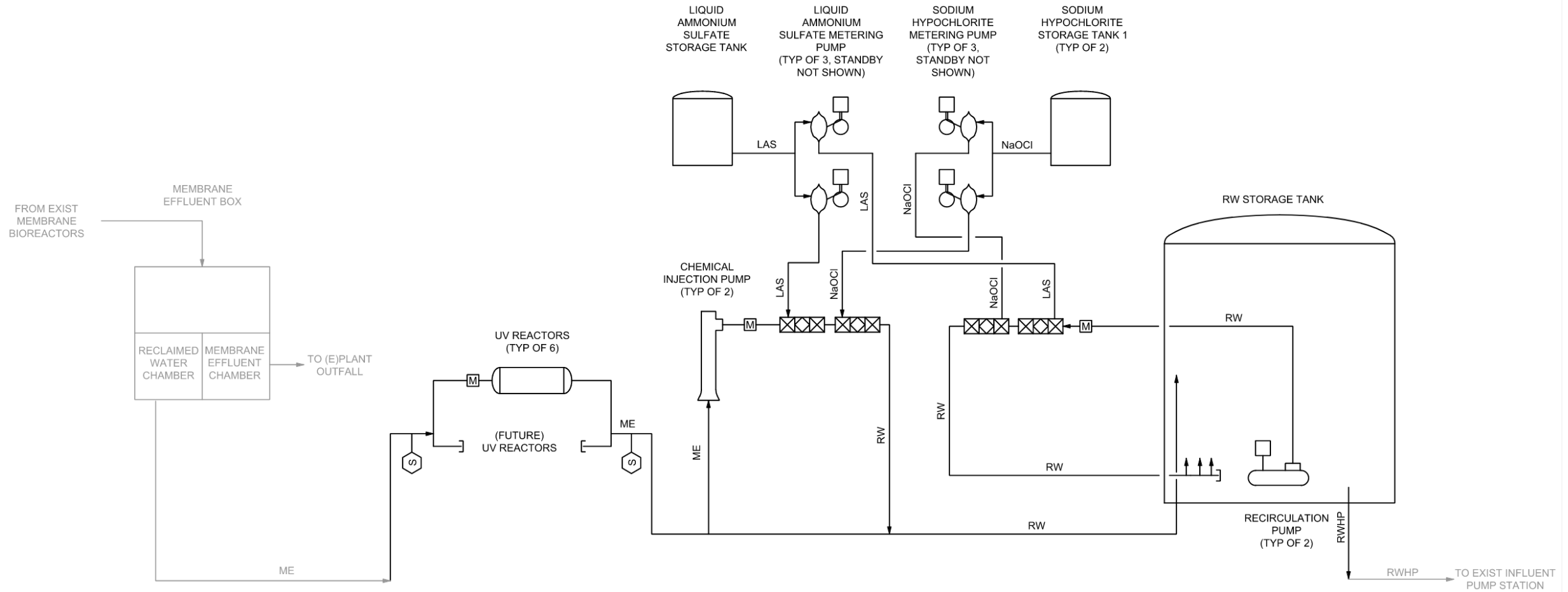

# Project Facilities

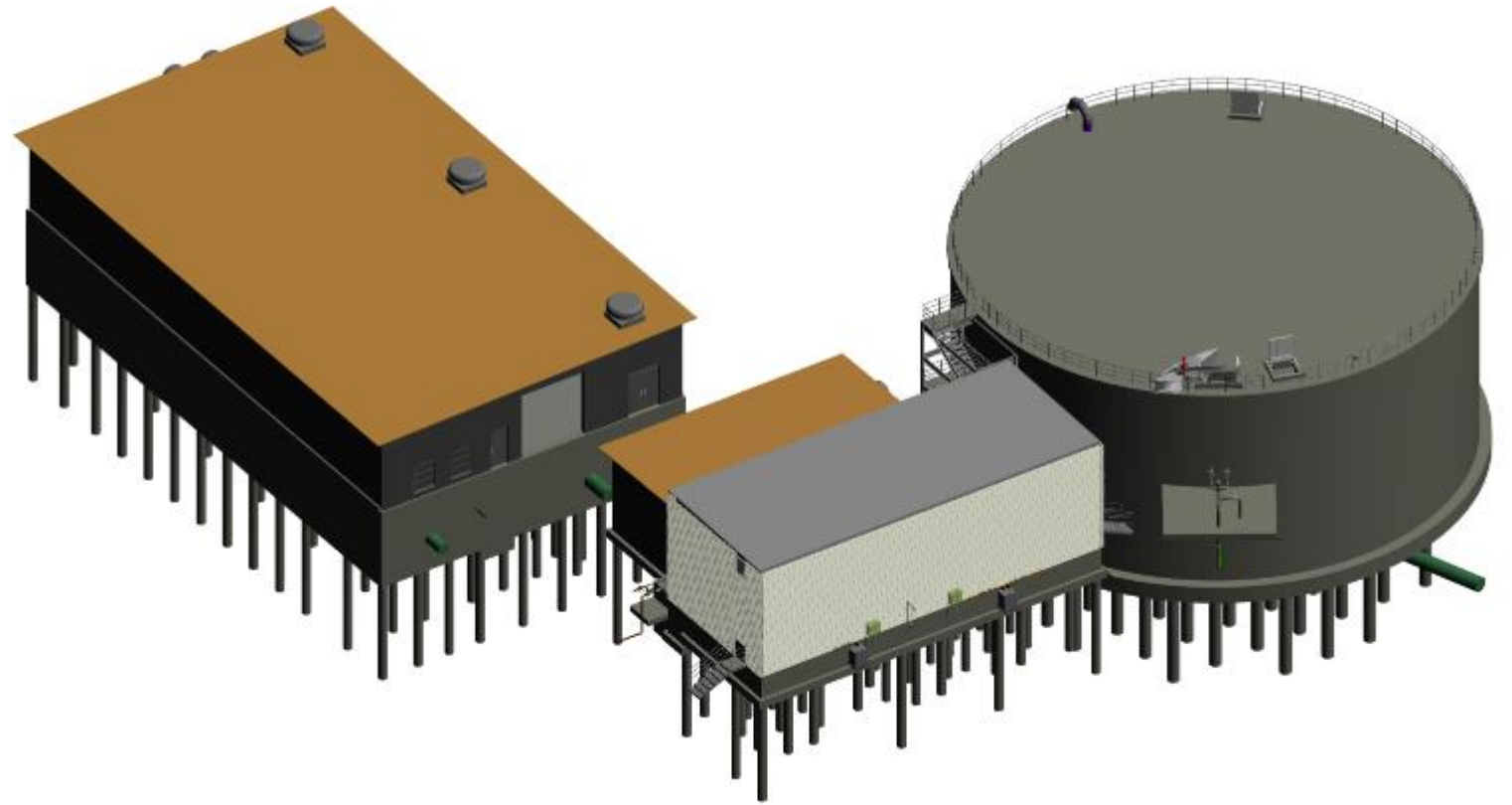
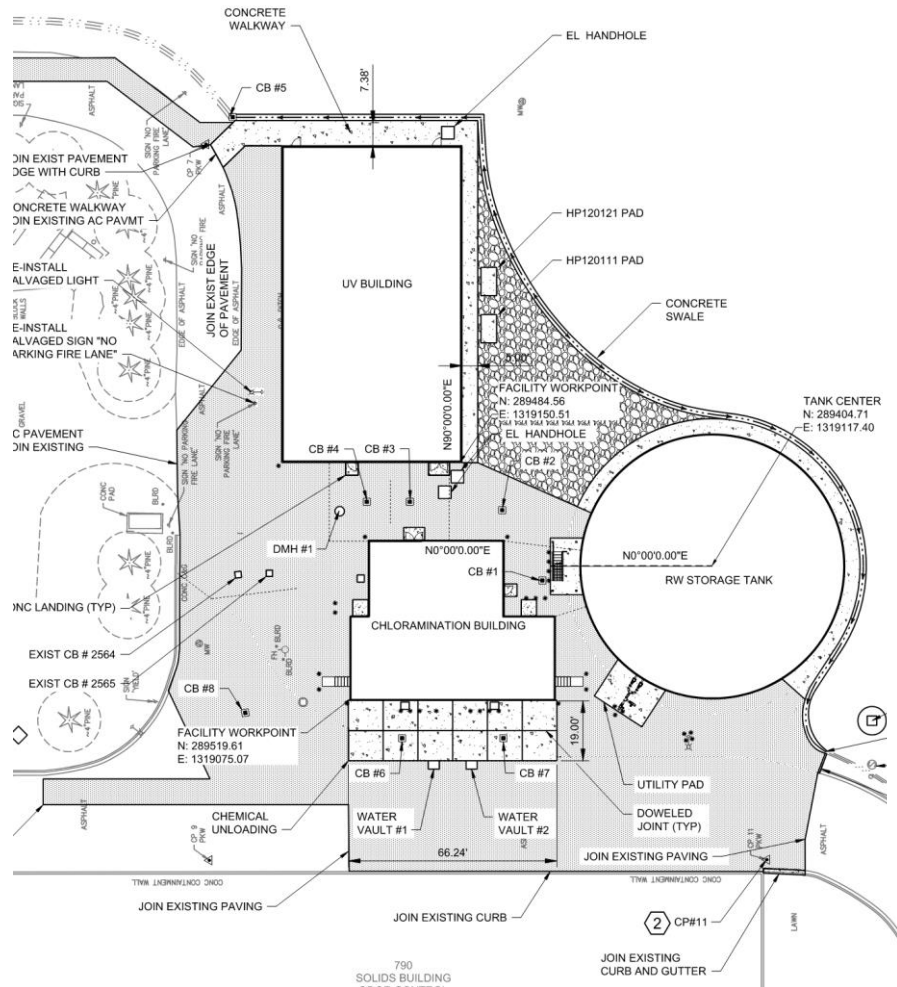



# What Equipment Was Preselected

UV closed vessel system:

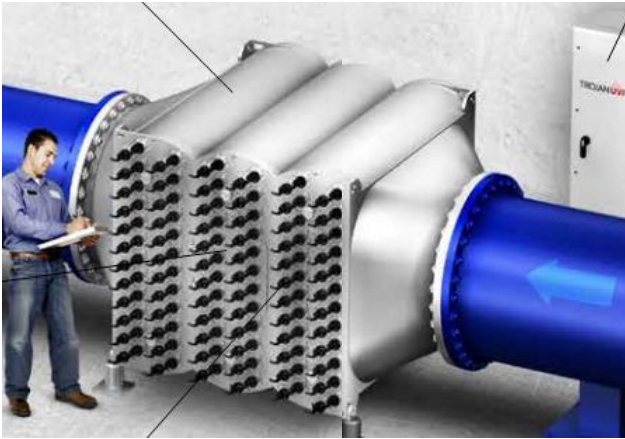

# Why This Equipment Was Preselected

- ✓ Experience and references
- ✓ Operations and Maintenance
- ✓ Life cycle cost

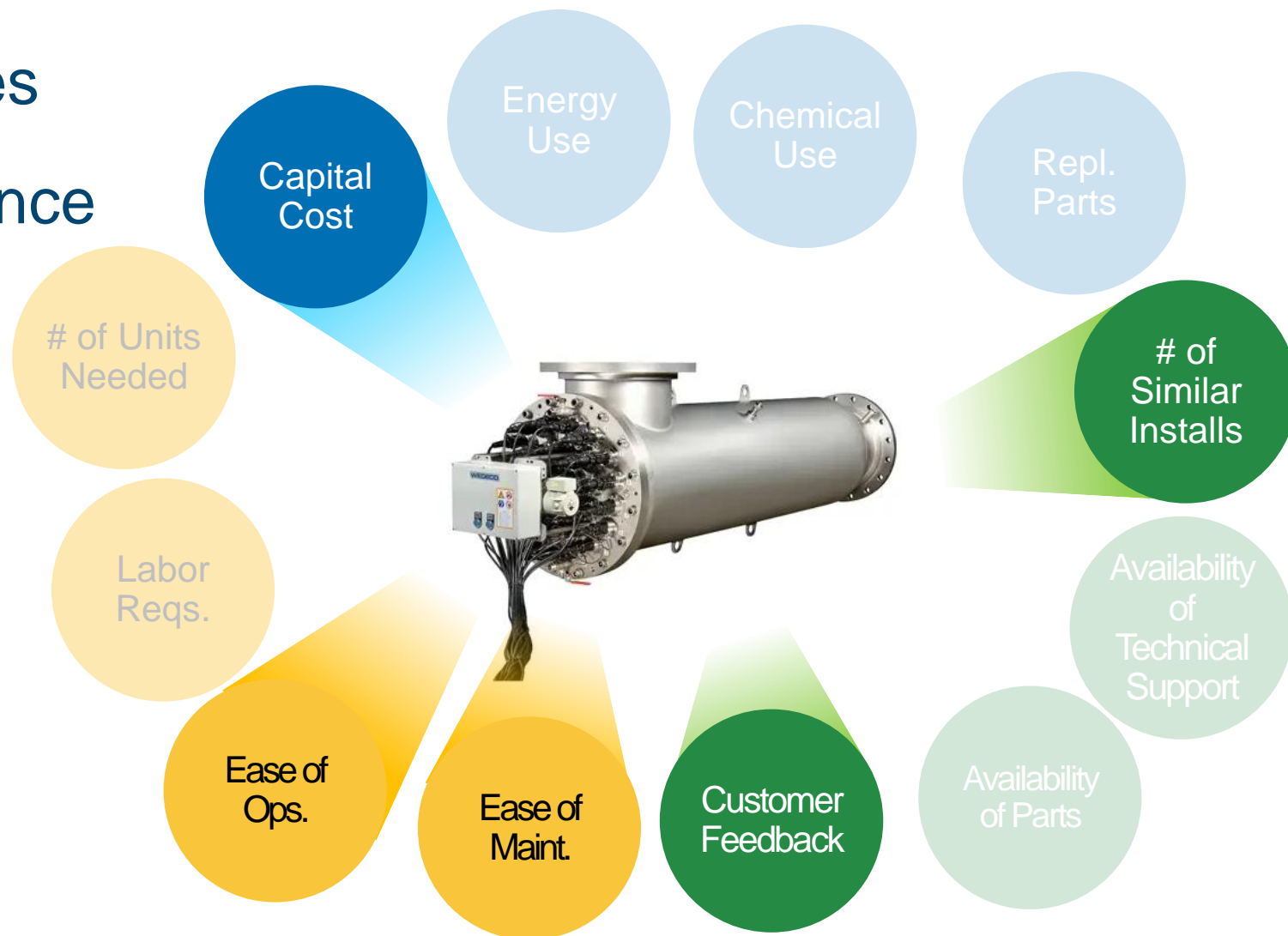

# How This Equipment Was Preselected

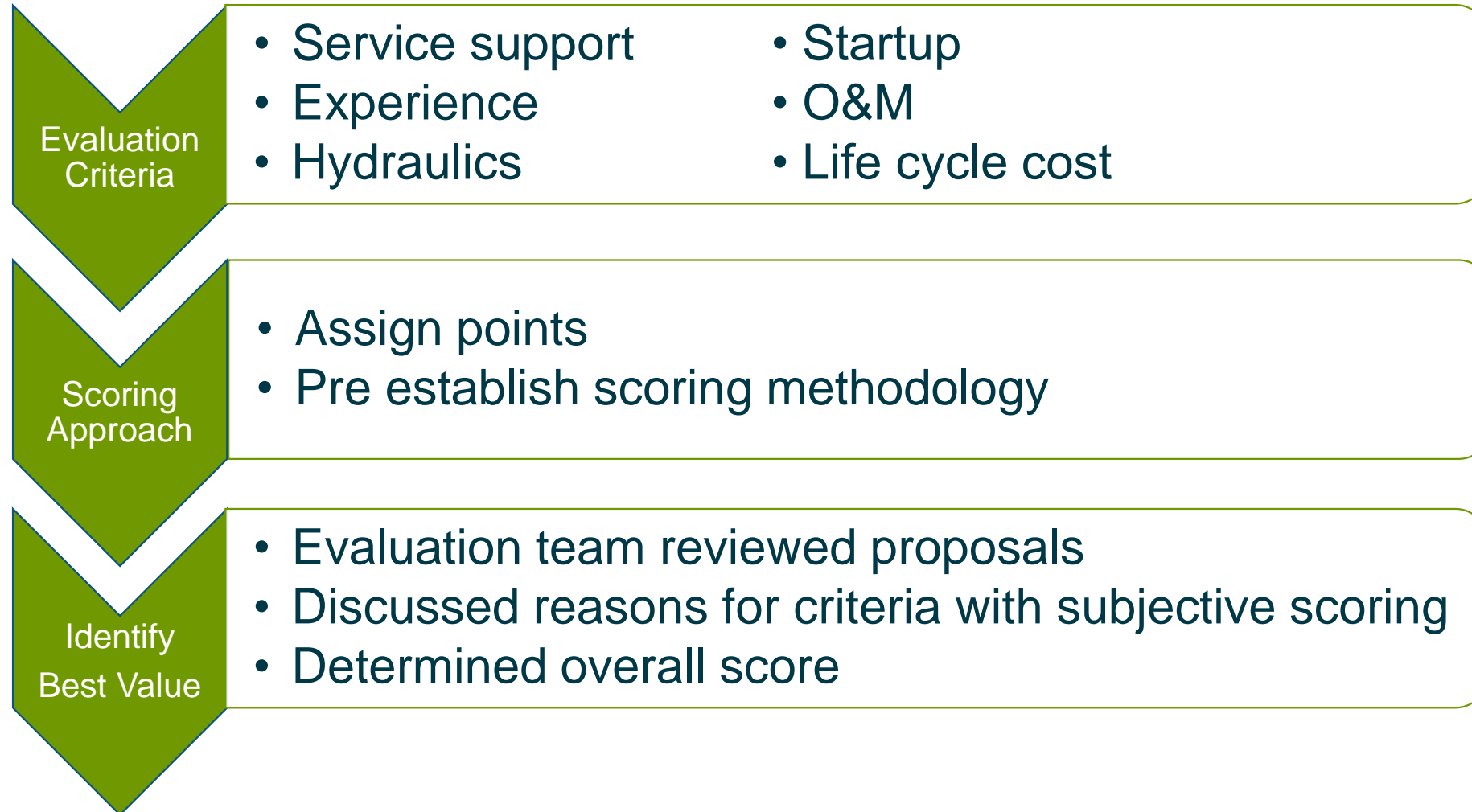

# Steps of Preselection Process

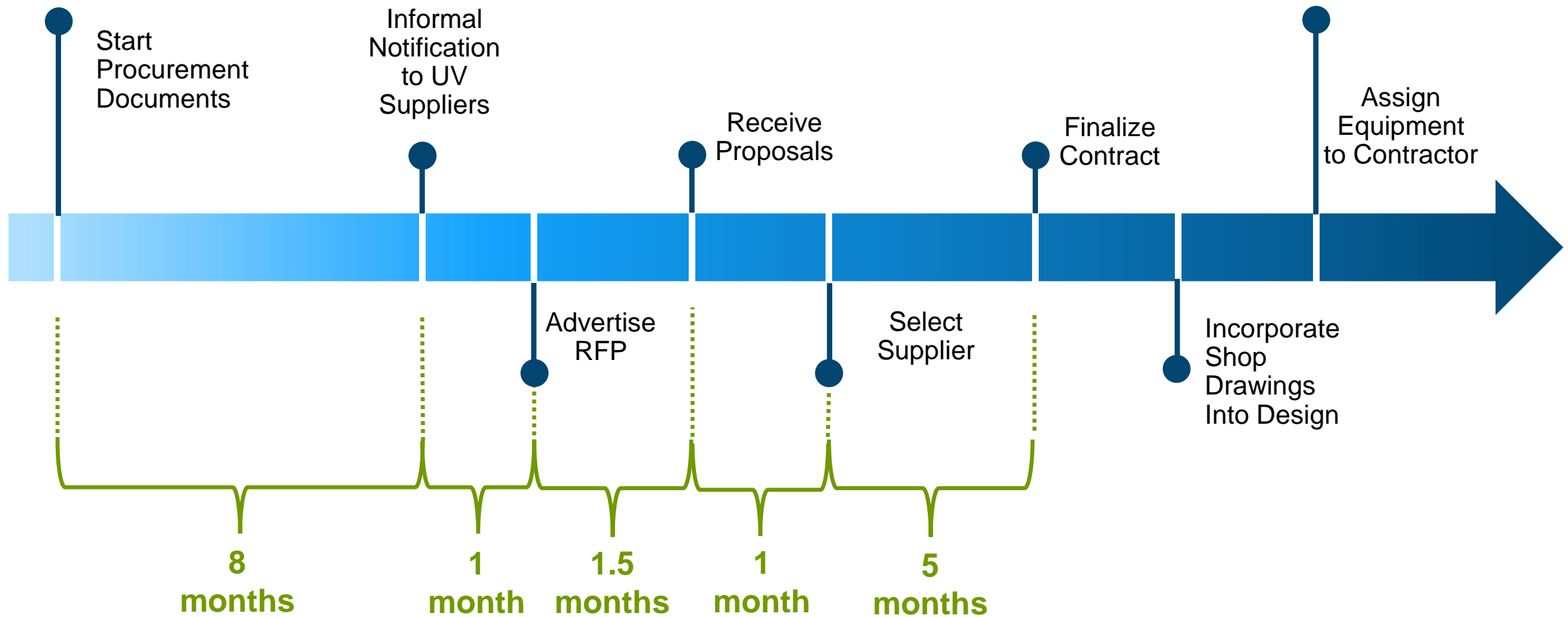

# Results: UV Preselection

- ✓ 3 proposals received
- ✓ Proposals were competitive/complete
- ✓ Awarded at \$1M



Xylem  
WEDECO LBX

# Lessons Learned: UV Preselection



Establish scoring methodology early

- ✓ Assign total points for each criteria
- ✓ Determine how points will be awarded

Take time to check references

- ✓ Establish phone questions and strategy to award points
- ✓ Appoint team member to handle reference calls who does not evaluate proposals

# Agenda



**Preselection 101**



**Case Study –  
Brightwater UV**

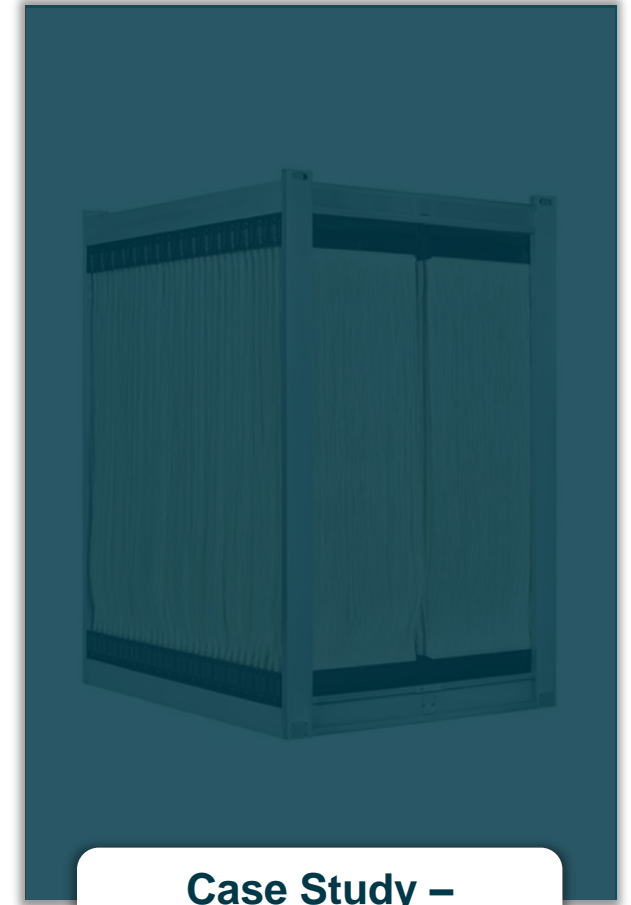

**Case Study –  
Ventura MBR/UV**



# Ventura Water Reclamation Facility

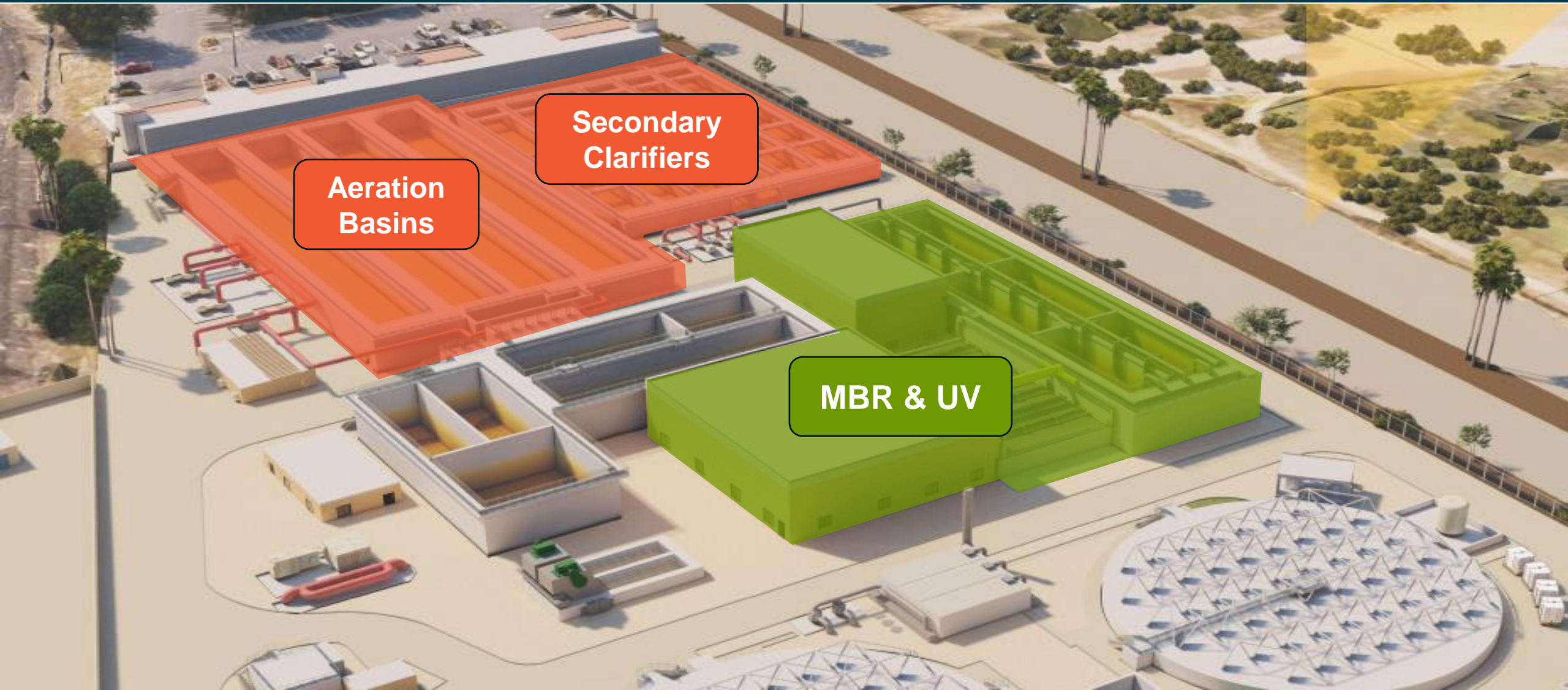

Aeration  
Basins

Secondary  
Clarifiers

MBR & UV



# Project Objectives

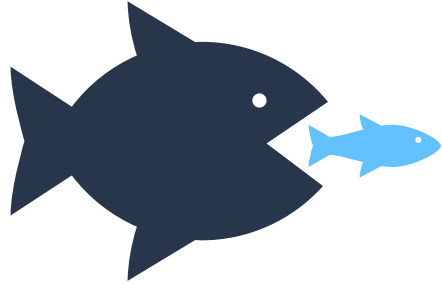

**Nitrogen Removal**



**Consent Decree**



**Budget Goal**

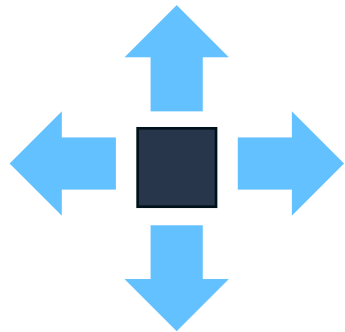

**Increased Capacity**



**Replace Aging  
Facilities**



**Future Potable  
Reuse**

# Process Flow Diagram

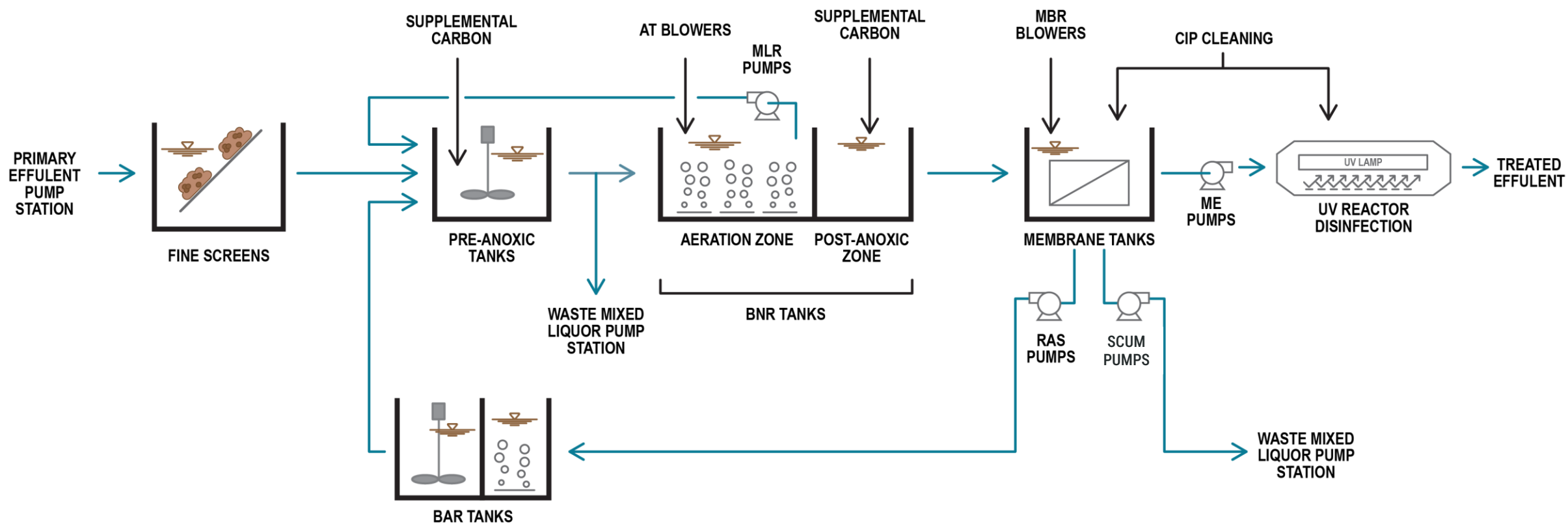

# What Equipment Was Preselected

## Membranes



Kubota  
SP900



DuPont  
B40N



Koch  
Pulsion LE44



Veolia  
ZW500D



Veolia  
ZW500EV

## UV

Wedeco  
LBX

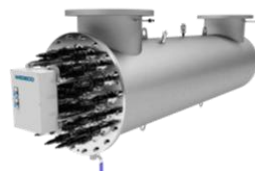

Trojan  
UVFlex

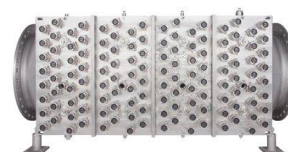
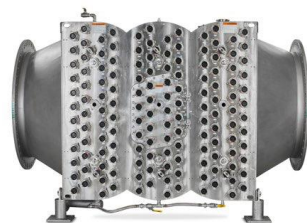

Evoqua  
UVLW



# Why This Equipment Was Preselected

- ✓ Life cycle cost
- ✓ Potable reuse readiness
- ✓ Experience
- ✓ Equipment layout

# Why This Equipment Was Preselected



**2 duty  
1 standby**

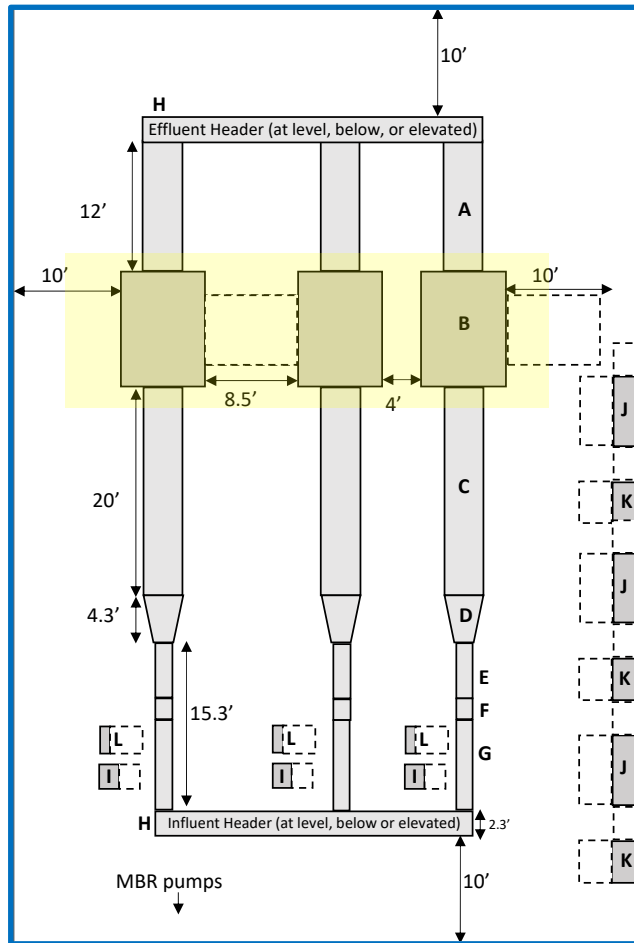

**Trojan  
UVFlex**

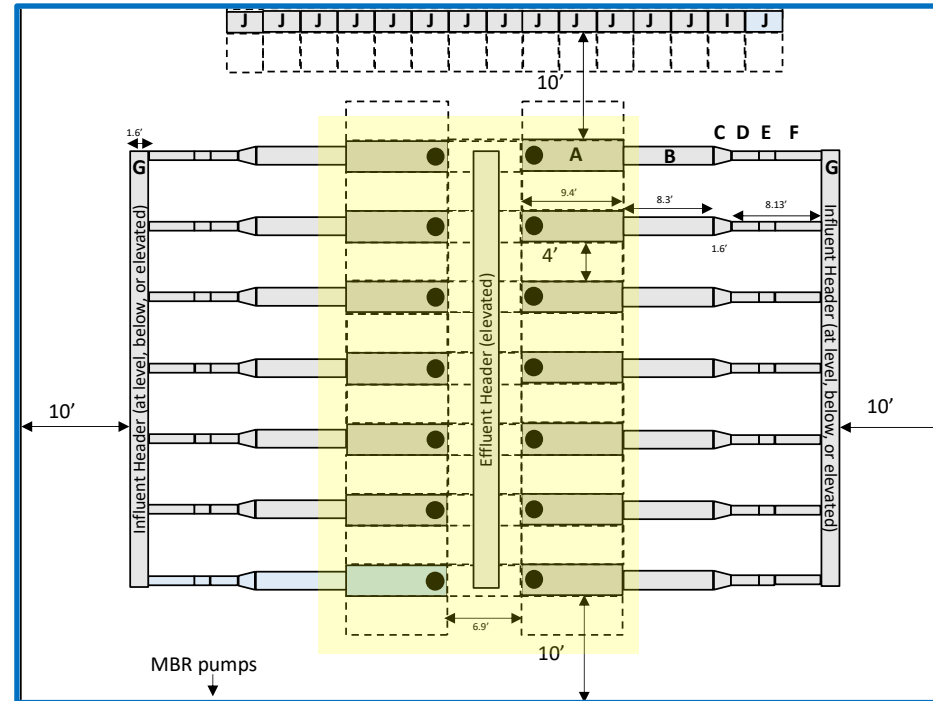

**Wedeco  
LBX**



**13 duty  
1 standby**

# How This Equipment Was Preselected

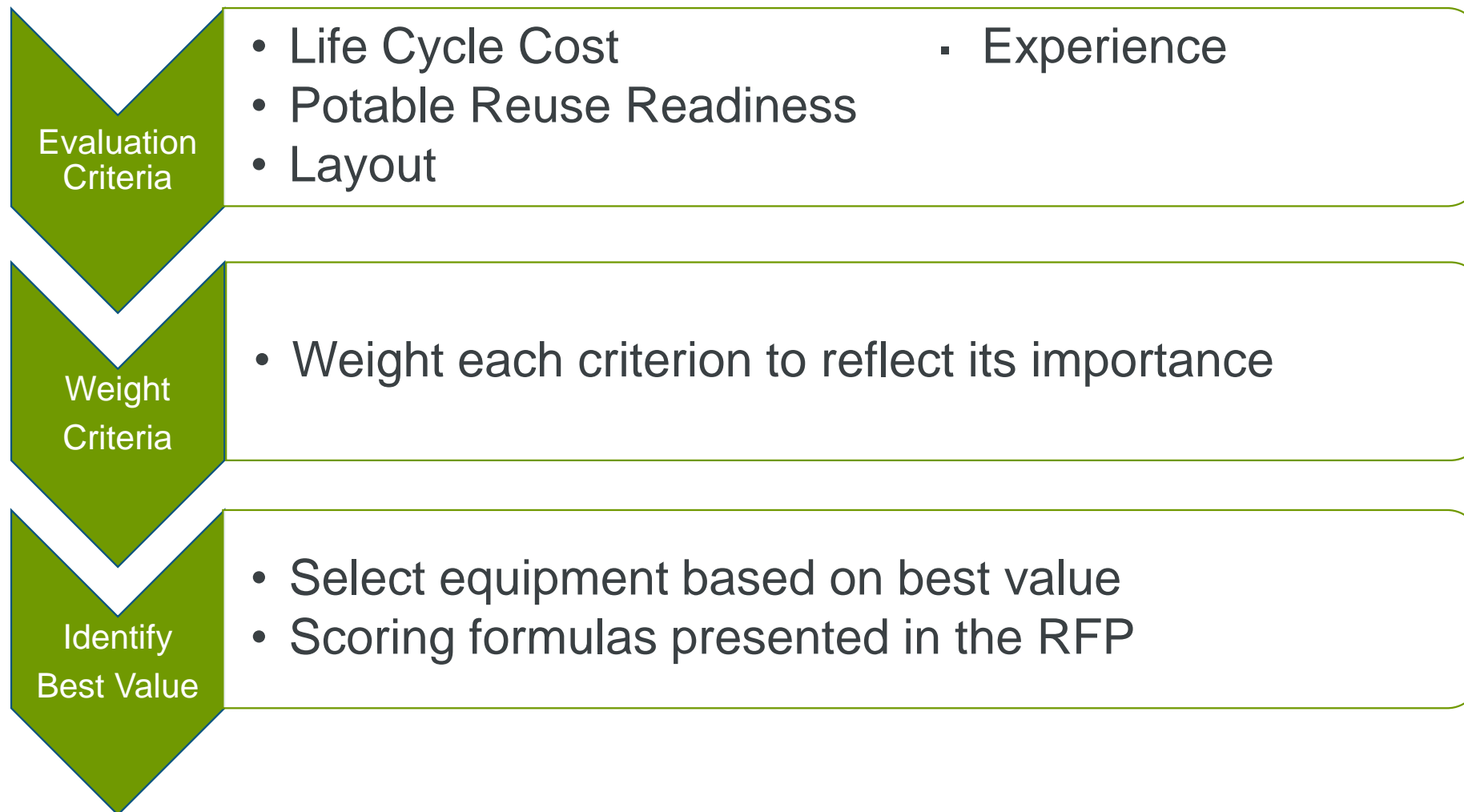

# Steps of Preselection Process

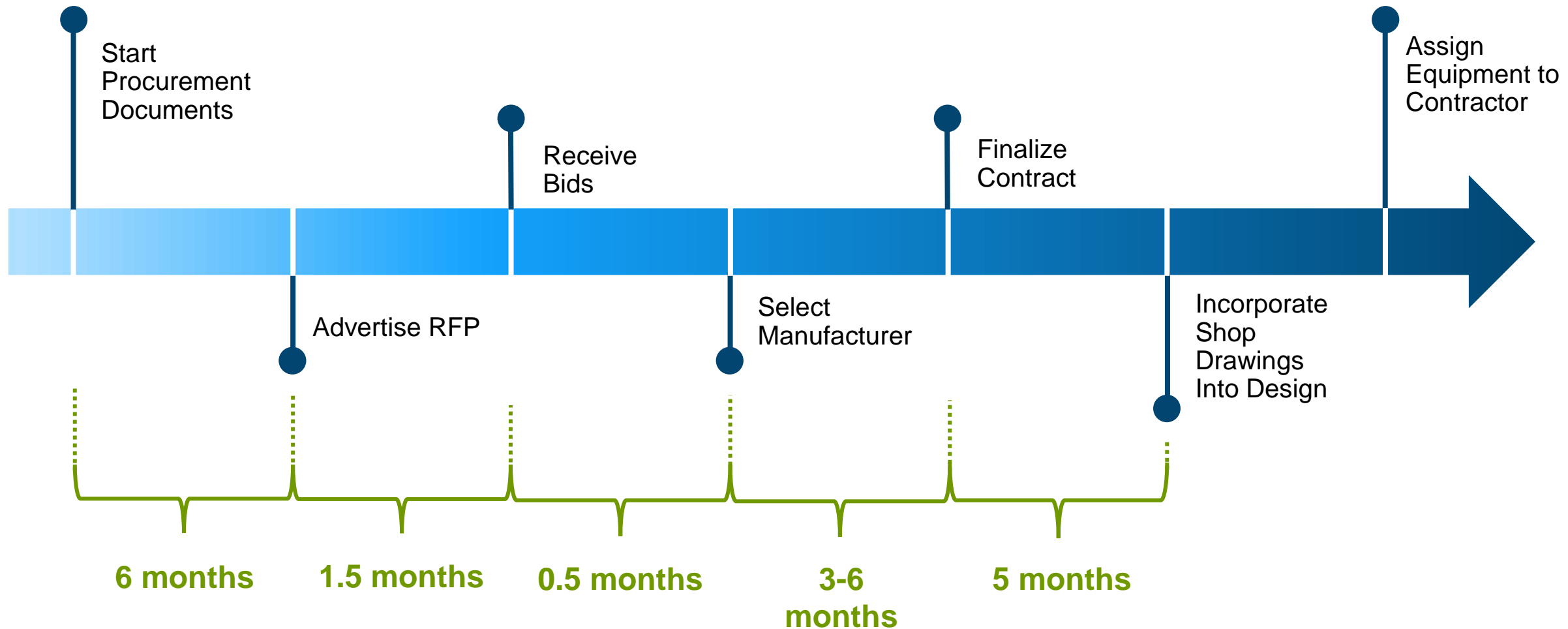

# Results: MBR Selection

- ✓ 4 equipment systems prequalified
- ✓ 3 manufacturers invited to submit
- ✓ 2 proposals received
- ✓ Proposals were competitive/complete
- ✓ Awarded at \$5.8M



Veolia  
ZW500EV



# Lessons Learned: MBR Preselection



Leave room for a proposer to surprise you

- ✓ Provide insight into how scores will be assessed but not an exact formula
- ✓ Formulaic scoring approach may discourage participation

# Results: UV Preselection

- ✓ 2 manufacturers prequalified
- ✓ 2 proposals received
- ✓ Proposals received were competitive/complete
- ✓ Awarded at \$2.9M

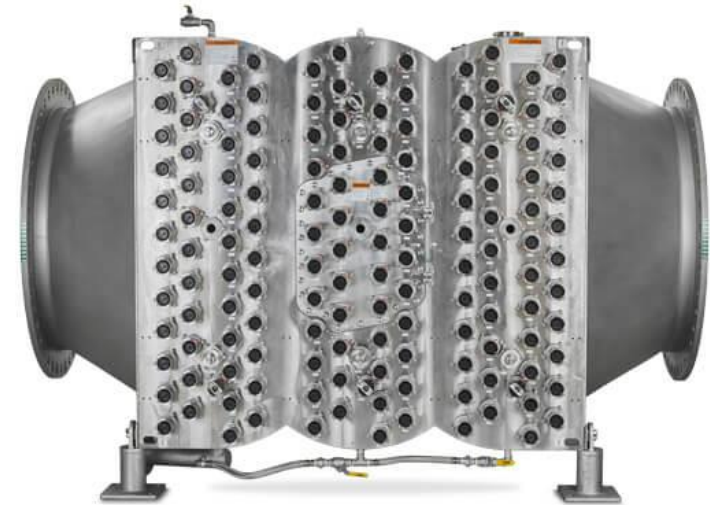

Trojan  
UVFlex



# Lessons Learned: UV Preselection

Assess what's most important and be prepared to compromise

- ✓ Allow proposers to review/comment on RFP before advertisement
- ✓ Proposers submit requests to change T&C with their bid (redline strikeout)
- ✓ Have attorney on standby to review requests when bids are received

# Key Takeaways



- ✓ Not interchangeable
- ✓ Best value

- ✓ Select between 10-30%
- ✓ 6-12 months
- ✓ Owner PM, PE, procurement, O&M, legal involved

- ✓ Scoring methodology
  - ✓ References
  - ✓ Proposal scoring
  - ✓ Negotiating T&Cs

# Q&A

---

**David Seymour**

[DavidSeymour@KennedyJenks.com](mailto:DavidSeymour@KennedyJenks.com)

**Alison Payauys**

[APayauys@Carollo.com](mailto:APayauys@Carollo.com)



American Water Works Association  
**Pacific Northwest** Section



Kennedy Jenks

