

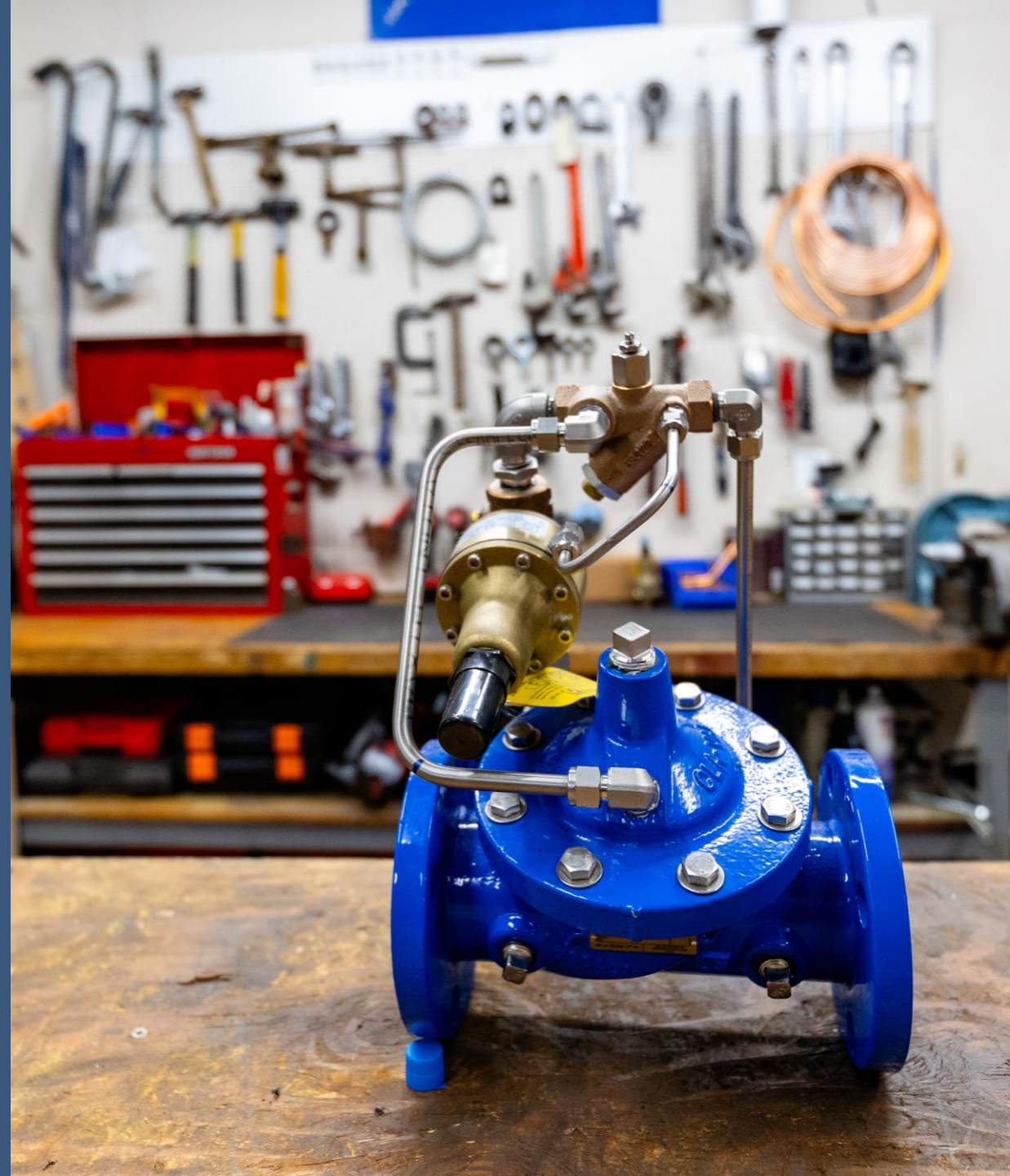

Cimco-GC
SYSTEMS

Hands-On With Hydraulic Controls Valves

Part 2: Maintenance



Previously On:

- Introduction to Cimco-GC Systems and Cla-Val
- Why Control Valves? Hydraulics 101
- Control Valve Main Body
- Intro to Pilot Systems
- Pressure Reducing Valves
- Pressure Relief Valves
- Pressure Sustaining Valves



What's on tap for this section:

- Introduction to Cimco-GC Systems and Cla-Val
- Principle of Operations Review
- Control Valve Main Body Parts
- Control Valve Maintenance Overview
- 90-01 Parts & CRD
- 50-01 Parts & CRL



Don't be afraid to ask questions!

How do I...?

What is the best way to...?

What does it mean when my valve is...?

How can I improve...?

Can I go the bathroom?

How do I keep my spouse happy??

What is the meaning of life??!!





Cimco-GC
SYSTEMS



Puyallup, Washington



40+ years in control valves



Technical support and service



Maintenance, troubleshooting, startups



Pressure reducing valves and stations



Cimco-GC
SYSTEMS





Raeann Velasquez
CEO



Carol Wells
Founder (retired)



Rob Velasquez
Cla-Val Design
and Quoting



Sarah Sleight
Valmatic Design
and Quoting



Teri Todd
Cla-Val Parts and
Order Tracking



Beau Swet
Service and
Troubleshooting



Cimco-GC
SYSTEMS

How we support your region



Engineering/Design Support



Troubleshooting



Price and availability

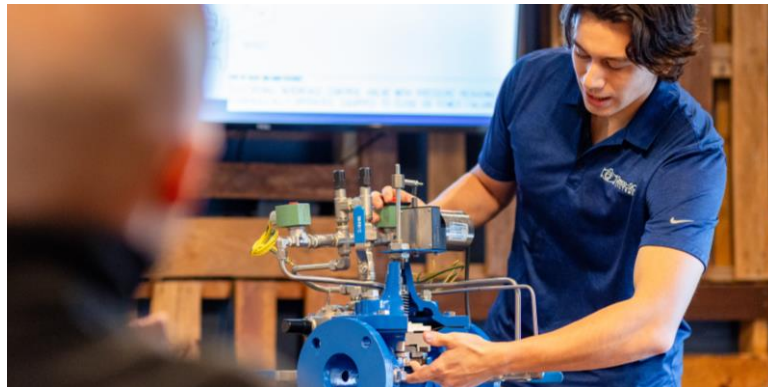

Outside Sales Support



Only factory-authorized Cla-Val Service Team in WA, OR, ID and AK



Inventory: parts, pilot, valve bodies through 8"

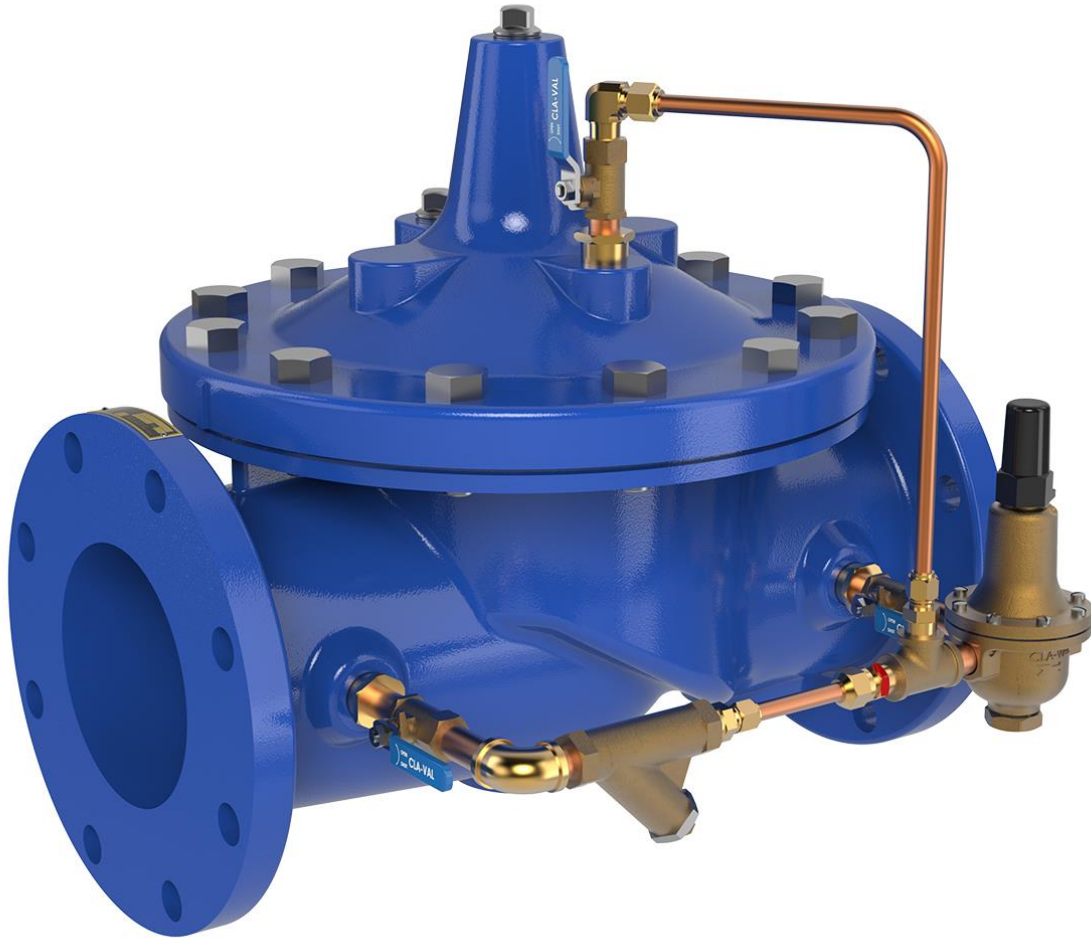

Cla-Val Overview

Global HQ: Costa Mesa, California
cla-val.com

Cla-Val Automatic Control Valves

- Founded by Donald G. Griswold 1936
- Based out of Costa Mesa, CA
- Only control valve manufacturer in the US
- Only one generation of valves (no additional phases, styles, etc.)
- Preferred brand worldwide



Cla-Val Factory Tours and Training

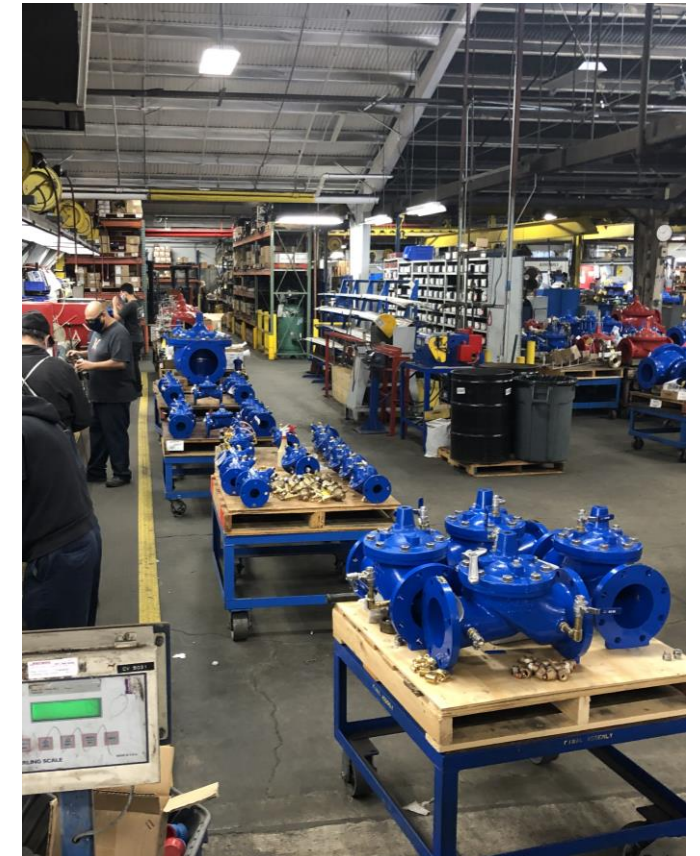



Cimco-GC
SYSTEMS

Questions?



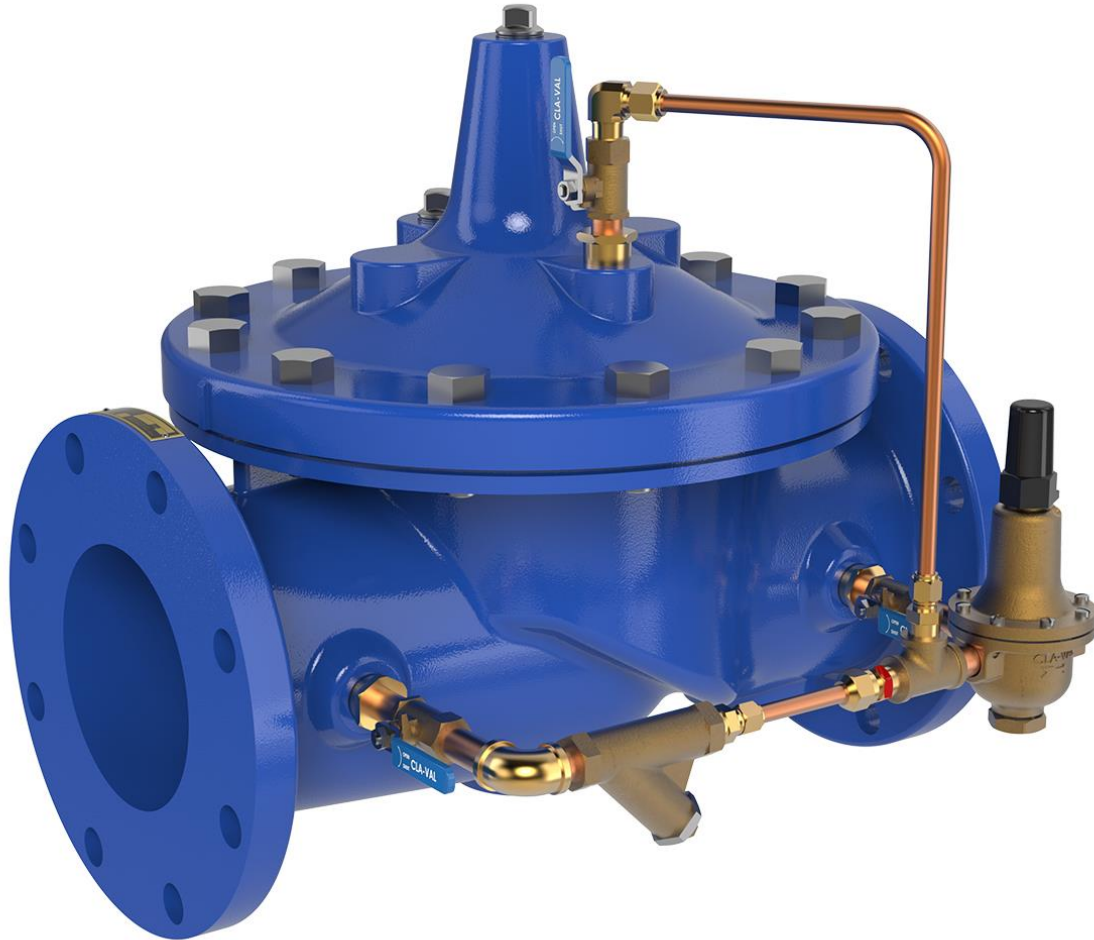

Basic Principles of Control Valves

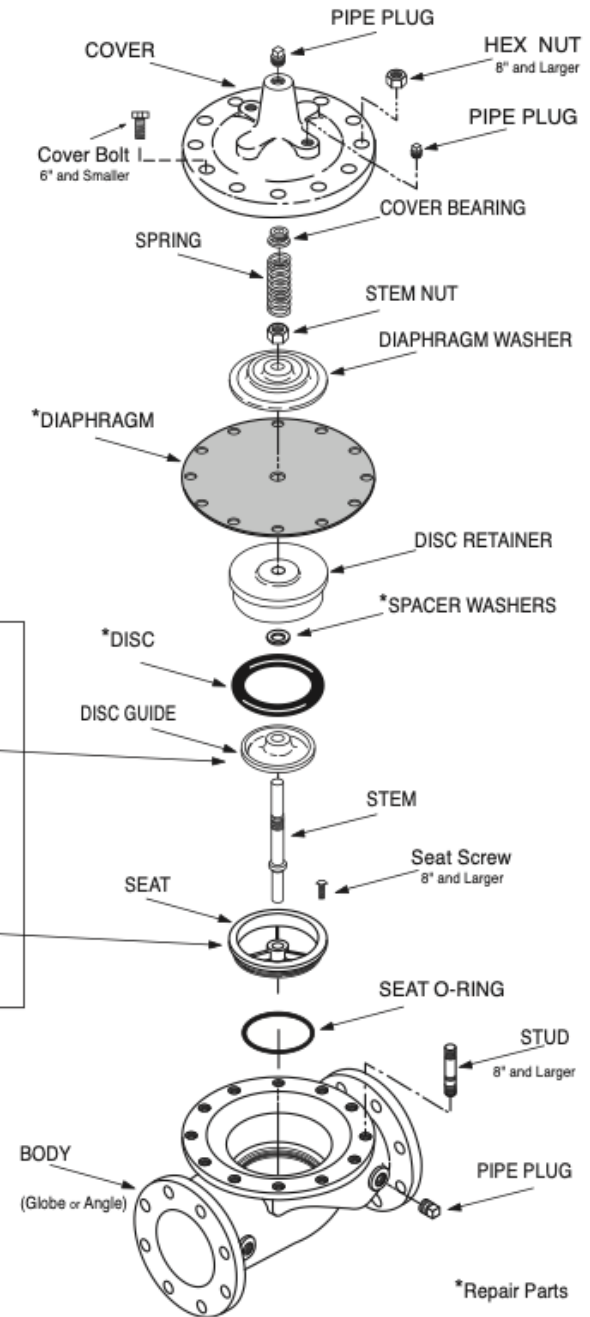
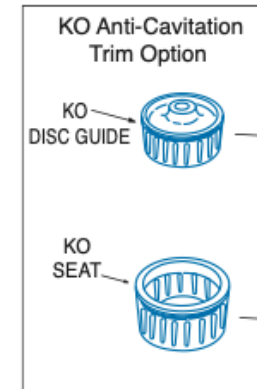
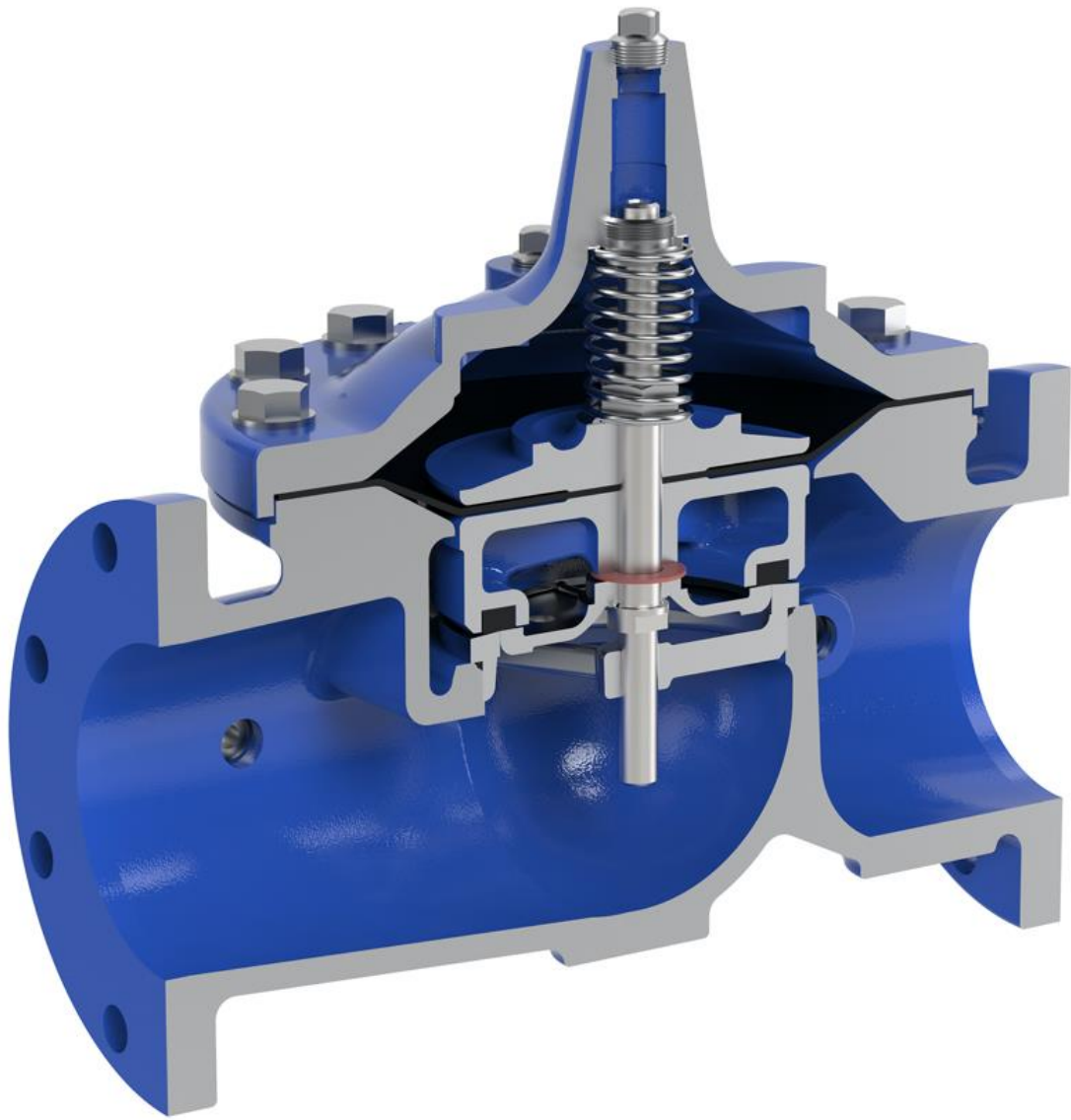

Standard Flow

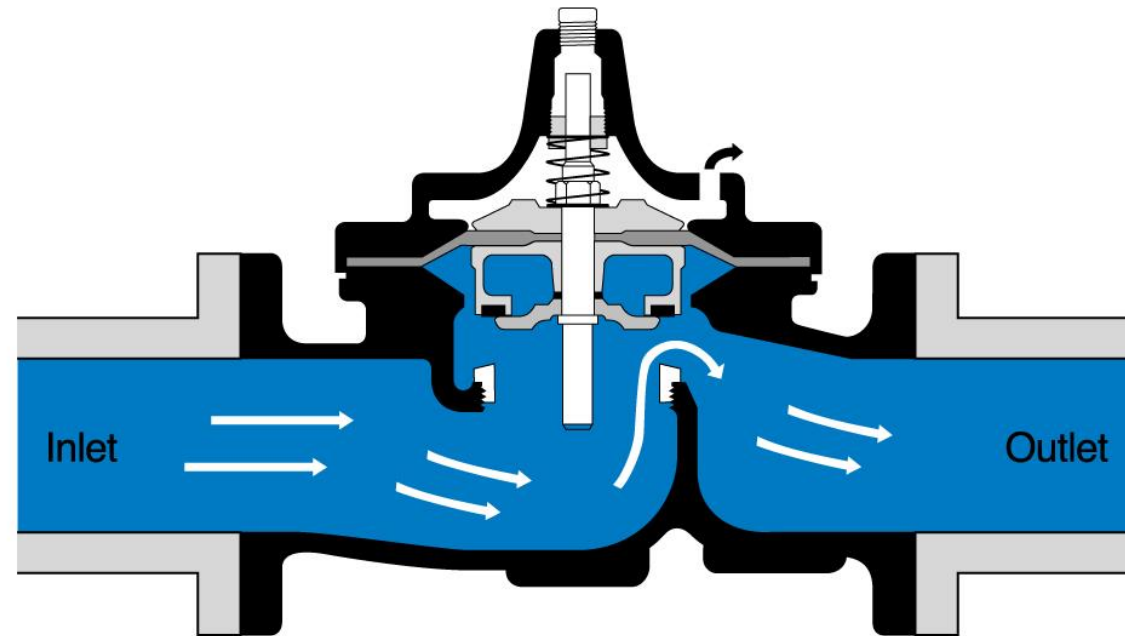

Up and Over Seat



Principles of Operation

Full Open

When pressure in the cover chamber is relieved to a zone of lower pressure, the line pressure at the valve inlet opens the valve, allowing full flow.

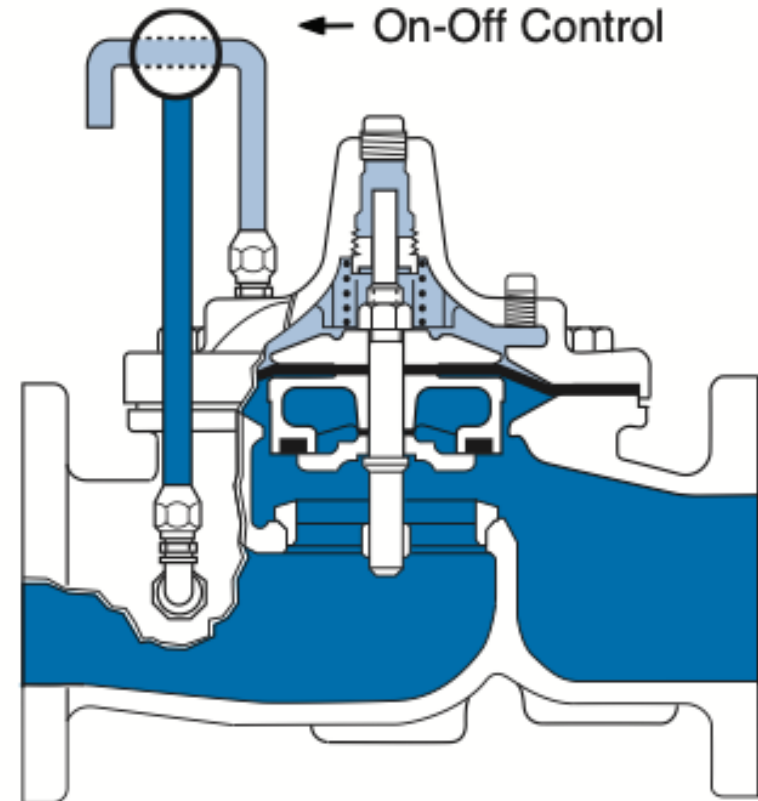

Principles of Operation

Tight Closing

When Pressure from the valve inlet is applied to the cover chamber, the valve closes drip tight.

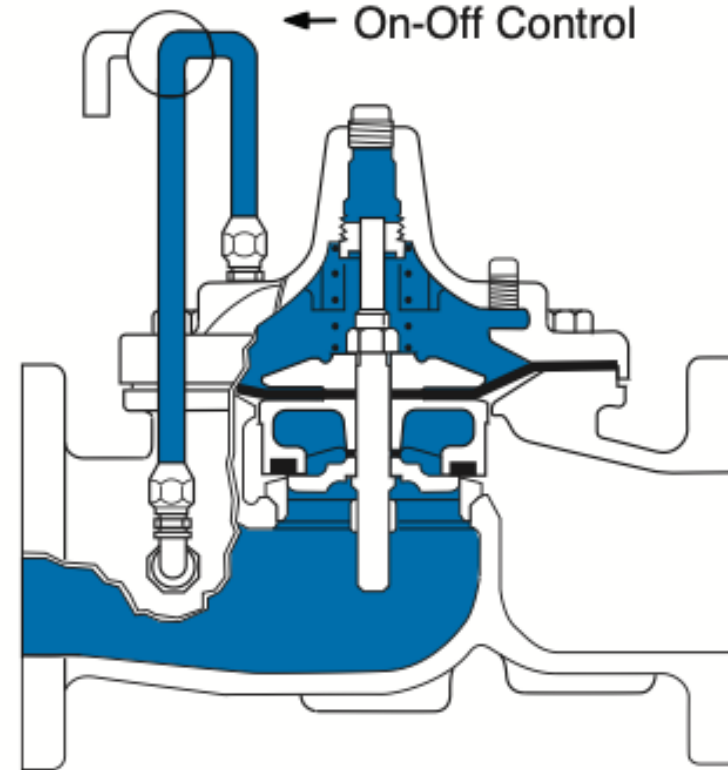

Principles of Operation

Modulation

The valve holds any intermediate position when operating pressures are equal above and below the diaphragm.

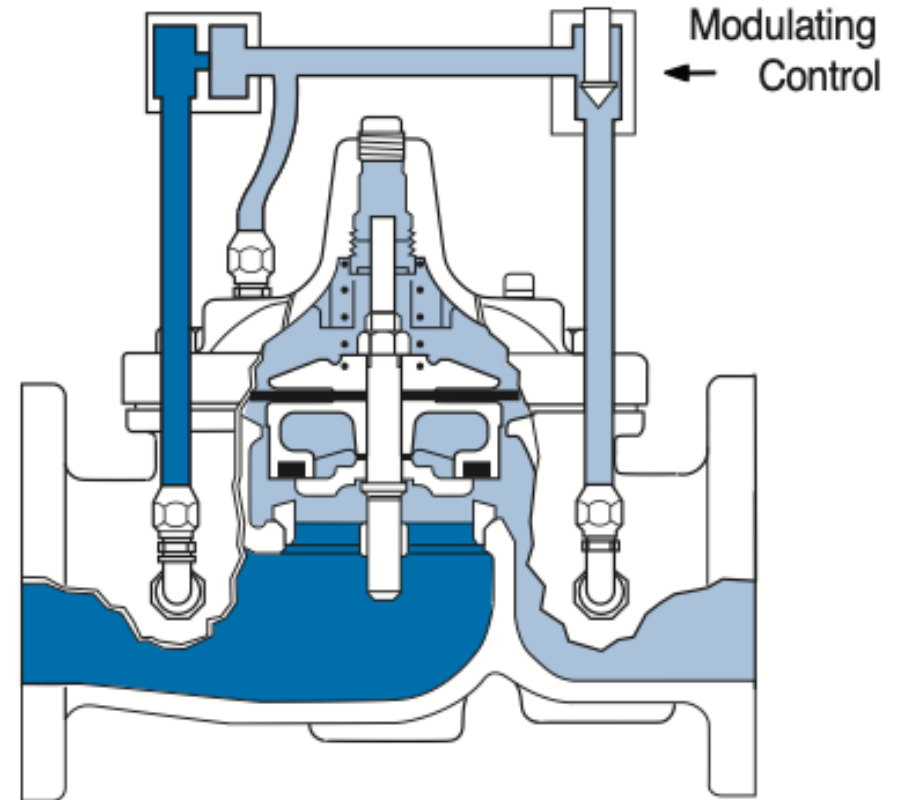

Line Pressure to Open – Opening Force

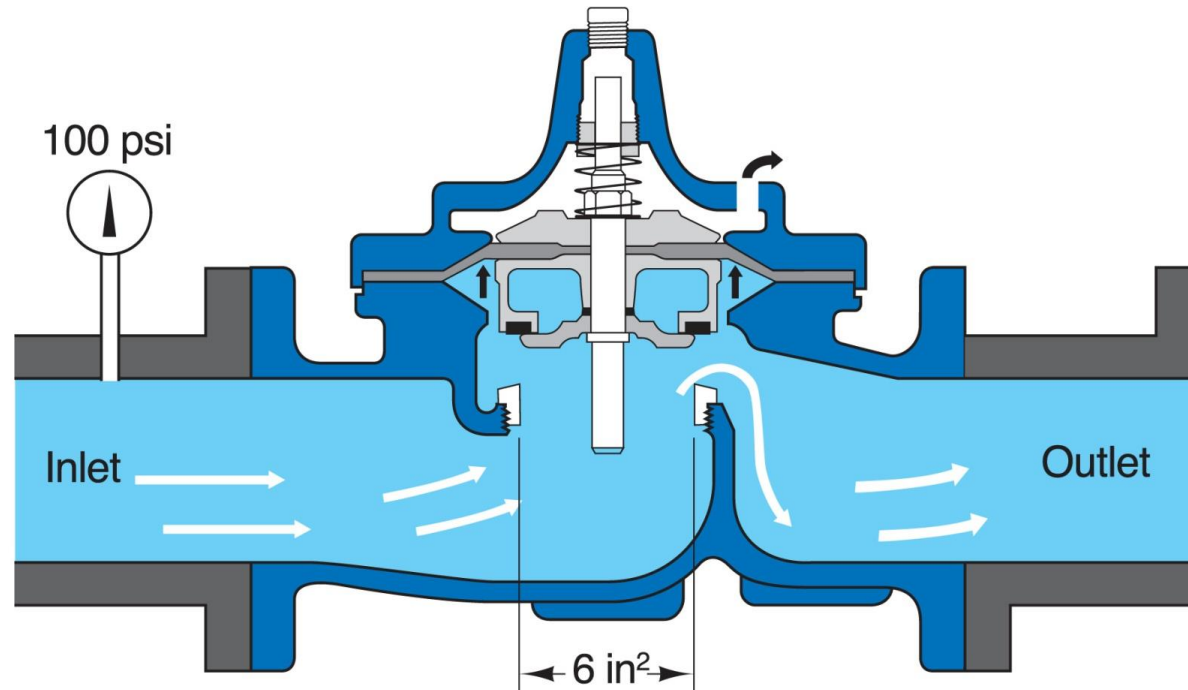

$$100\text{psi} \times 6 = 600\text{lbs.}$$

(opening force)

Line Pressure to Close – Closing Force

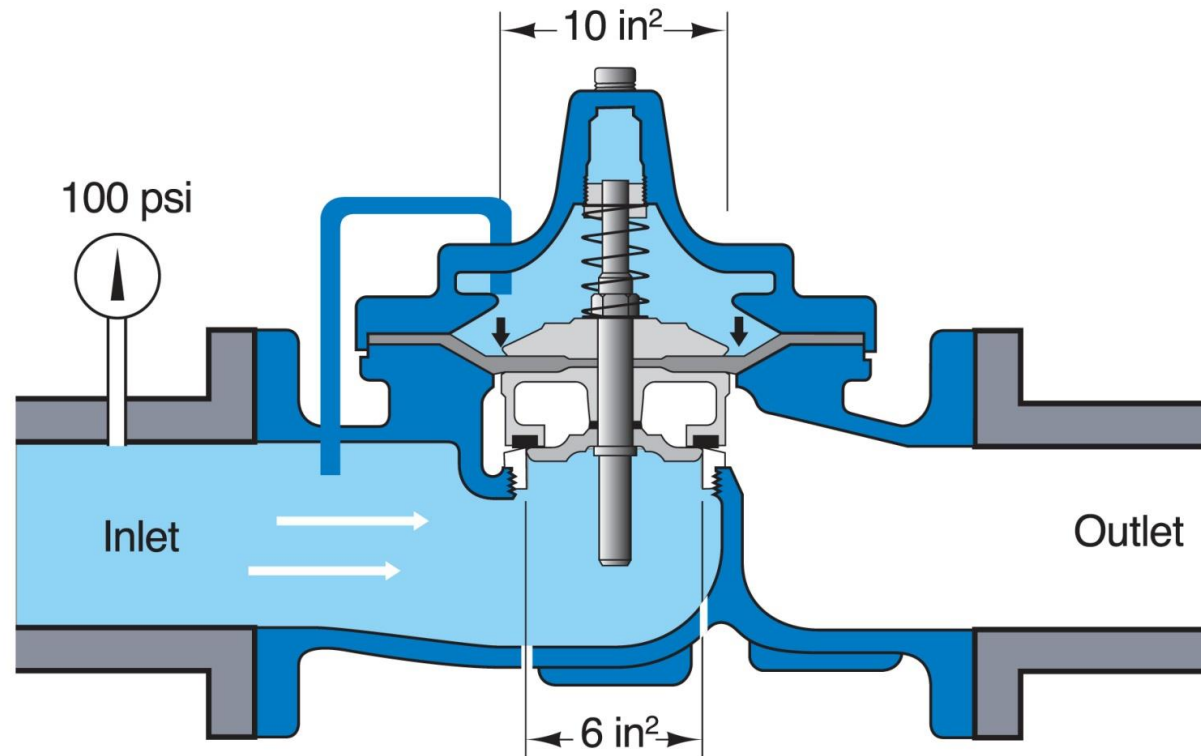

$$\begin{aligned} \text{Closing Force} & 100 \times 10 = 1000 \text{ lbs.} \\ \text{Opening Force} & 100 \times 6 = \underline{600 \text{ lbs.}} \\ \text{Difference} & = 400 \text{ lbs.} \end{aligned}$$

Hammer this in!

- Water on the cover valve goes closed
- Water off the cover valve goes open
- Remembering this will help when you have to troubleshoot



Control Valve Main Body

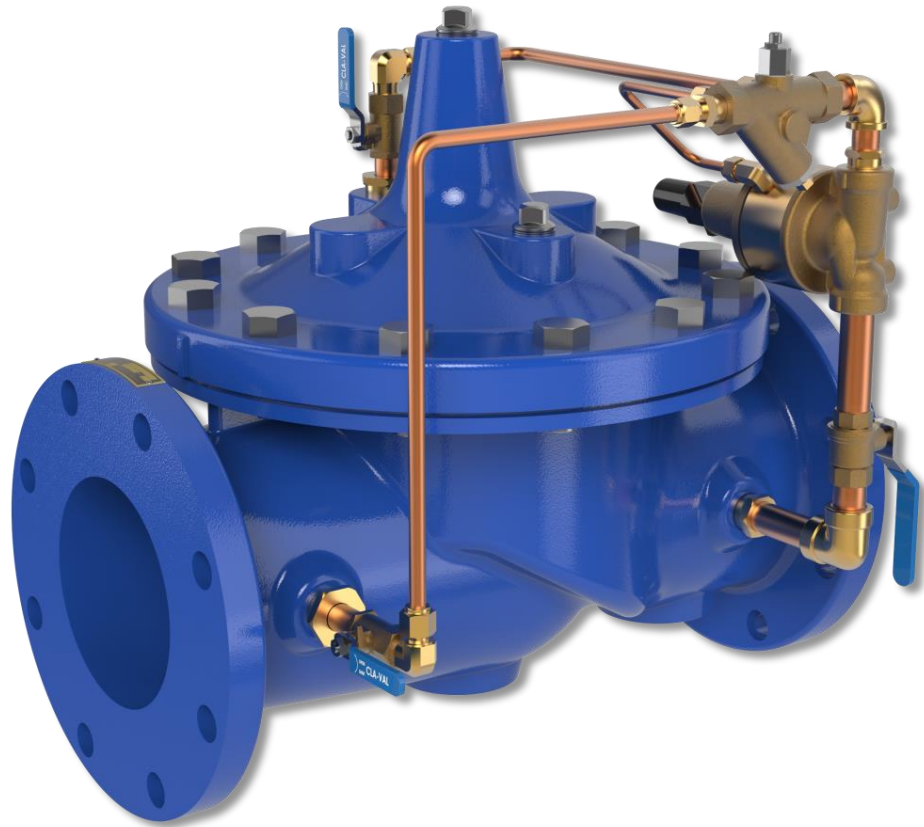

Complete Valve Installed

3 Main Area's

Main Valve Body



Disc /Diaphragm Assembly

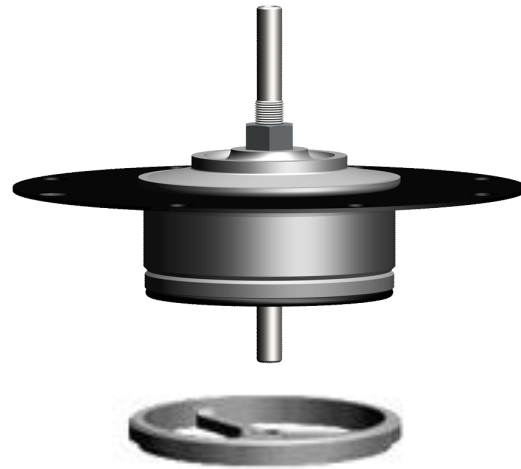

Seat

Pilot Control System

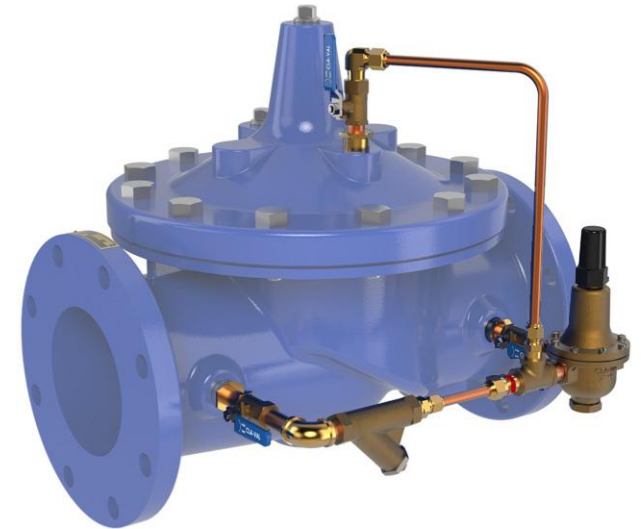

Main Valve Options – Connections

For our Industry:

- Threaded and flanged is common for valves 3" and below
- Flanged is standard for valves 4" and above
- 150# flanged is normal recommendation
- 300# flanged is for high pressures (250+ psi)

**150# and 300# flanges are not compatible.
Make sure your valve and pipeline flanges match!*

Pattern	Threaded	Flanged	Grooved End
Globe	3/8" - 3"	1 1/2" - 36"	1 1/2"-2"- 2 1/2"- 3"- 4"- 6"- 8"
Angle	1" - 3"	1 1/2" - 16" & 24"	2" - 3" - 4"

Pressure Ratings (Recommended Maximum Pressure - psi)

Valve Body & Cover		Pressure Class				
		Flanged			Grooved	Threaded
Grade	Material	ANSI Standards*	150 Class	300 Class	300 Class	End‡ Details
ASTM A536	Ductile Iron	B16.42	250	400	400	400
ASTM A216-WCB	Cast Steel	B16.5	285	400	400	400
UNS 87850	Bronze	B16.24	225	400	400	400

Note: * ANSI standards are for flange dimensions only.
Flanged valves are available faced but not drilled.
‡ End Details machined to ANSI B2.1 specifications.
Valves for higher pressure are available; consult factory for details

Main Valve Options – Materials

For our Industry:

- Ductile iron body with epoxy coating is the normal recommendation
- Bronze trim is being phased out. Stainless steel trim is the new standard
- Buna-N rubber is the norm, EPDM and Viton are available

Materials

Component	Standard Material Combinations		
Body & Cover	Ductile Iron	Cast Steel	Bronze
Disc Retainer & Diaphragm Washer	Cast Iron	Cast Steel	Bronze
Trim: Disc Guide, Seat & Cover Bearing	Bronze is Standard Stainless Steel is optional		
Disc	Buna-N® Rubber		
Diaphragm	Nylon Reinforced Buna-N® Rubber		
Stem, Nut & Spring	Stainless Steel		
For material options not listed, consult factory. Cla-Val manufactures valves in more than 50 different alloys.			

Main Valve Options – Materials Cont.

For harsh conditions:
316 stainless steel valve bodies
with full stainless steel internals and
stainless steel pilot systems
are readily available



Other Customer Specified Options

Special factory testing and documentation

- Mil thickness or Holiday Free

Special paint or coating

Special components in pilot system

- Example: speed controls, valve position indicator, stainless steel tubing and fittings

Special mounting pilot system

- Example: Remote left hand as opposed to right hand

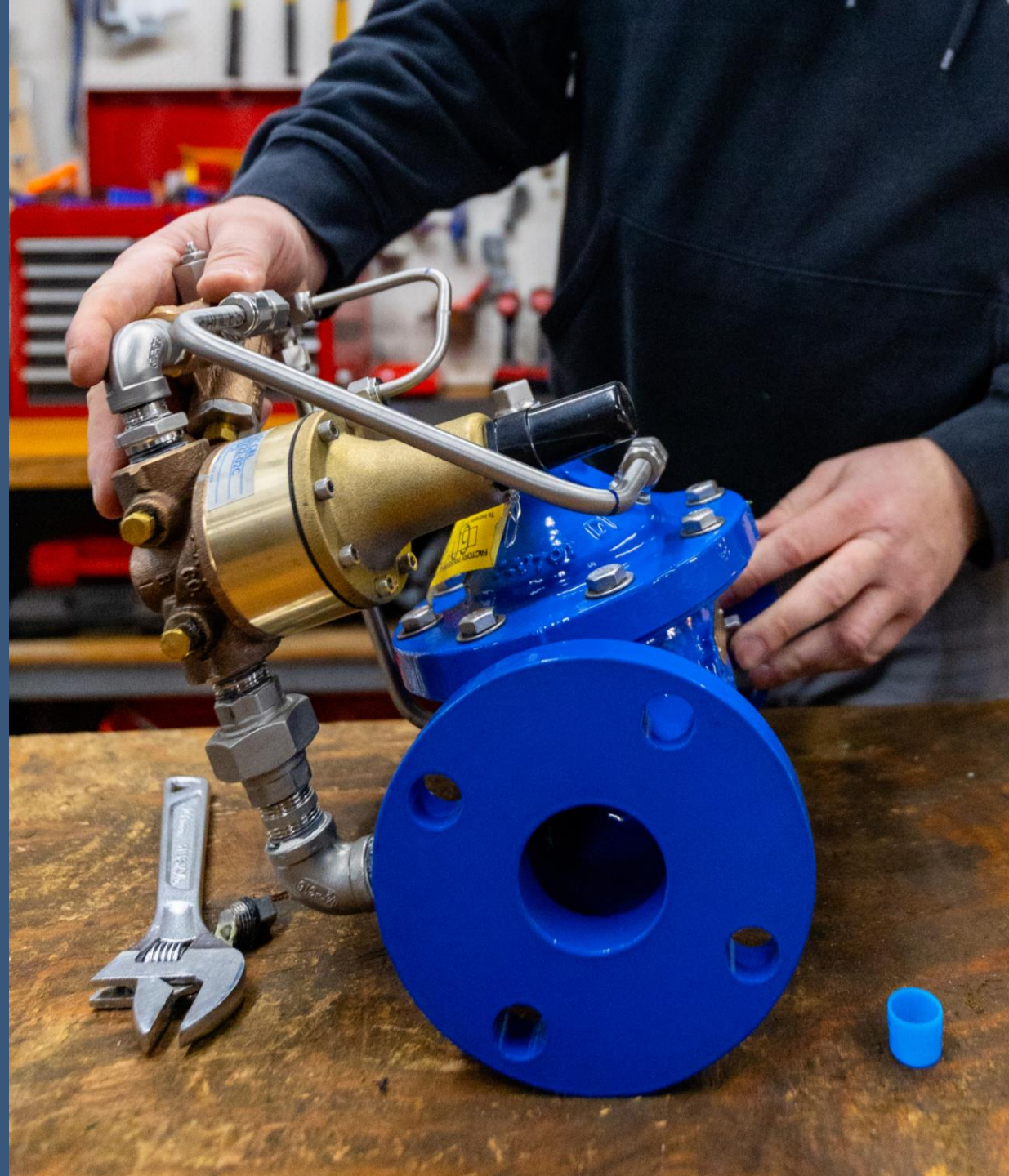



Left hand mount

If you take away nothing else...

- Water on the cover valve goes closed
- Water off the cover valve goes open

Remembering this will help you understand pilot systems and help when you have to troubleshoot

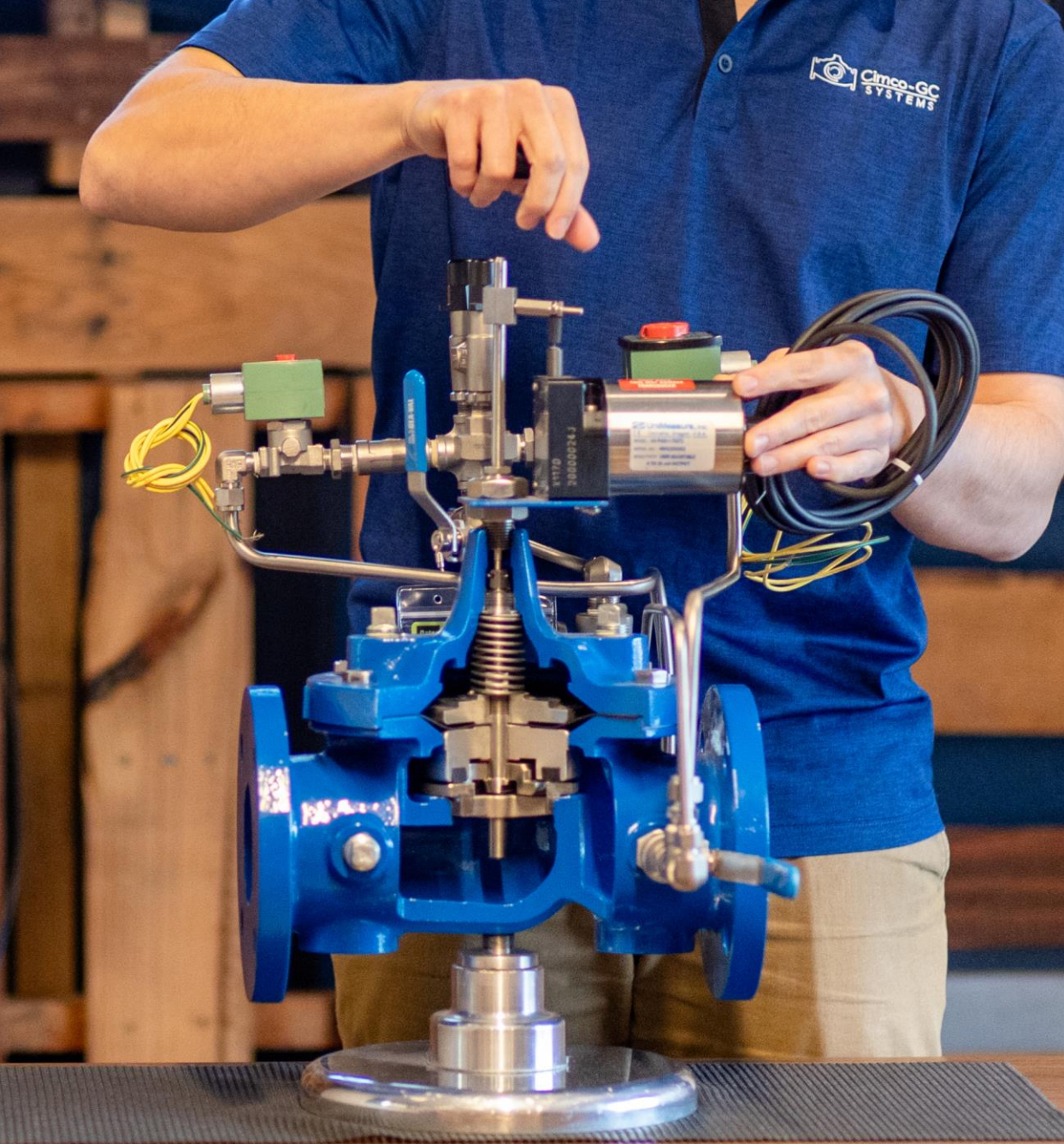

Cimco-GC
SYSTEMS

Main Control Valve Internals

Internal: Three Assemblies

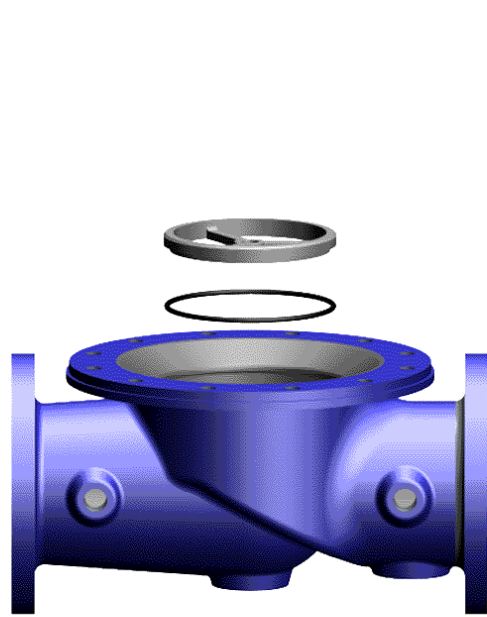

Valve Body & Seat Assembly



Diaphragm & Disc Assembly

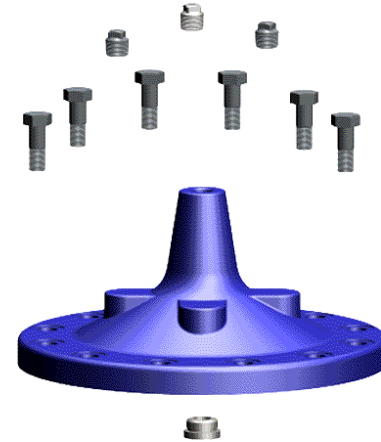

Cover & Bearing Assembly

Internals: Three Assemblies

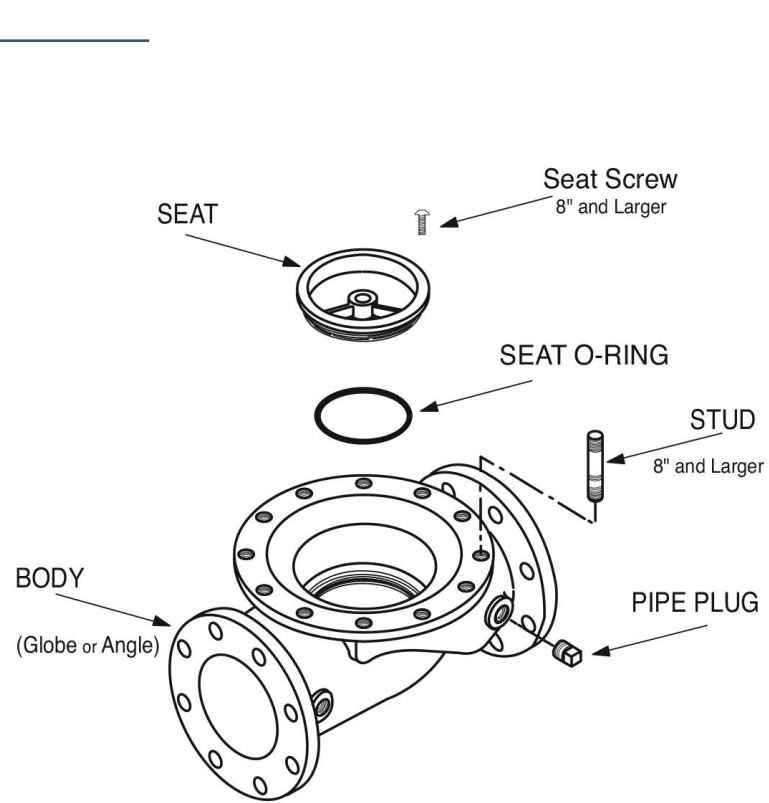

Valve Body & Seat Assembly

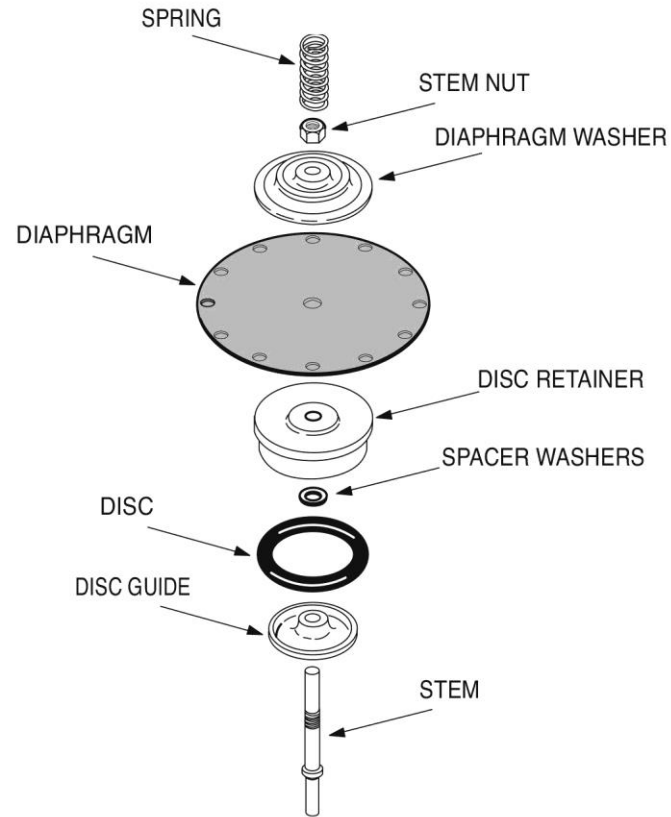

Diaphragm & Disc Assembly

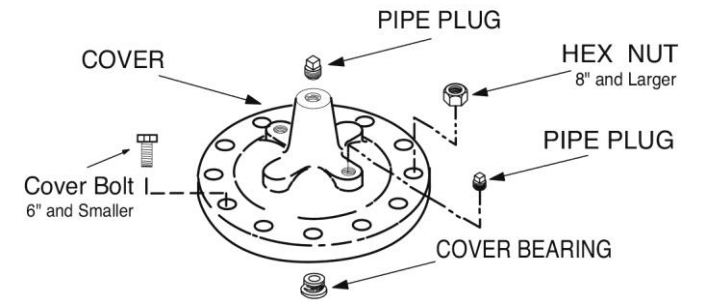

Cover & Bearing Assembly

Cover & Bearing Assembly

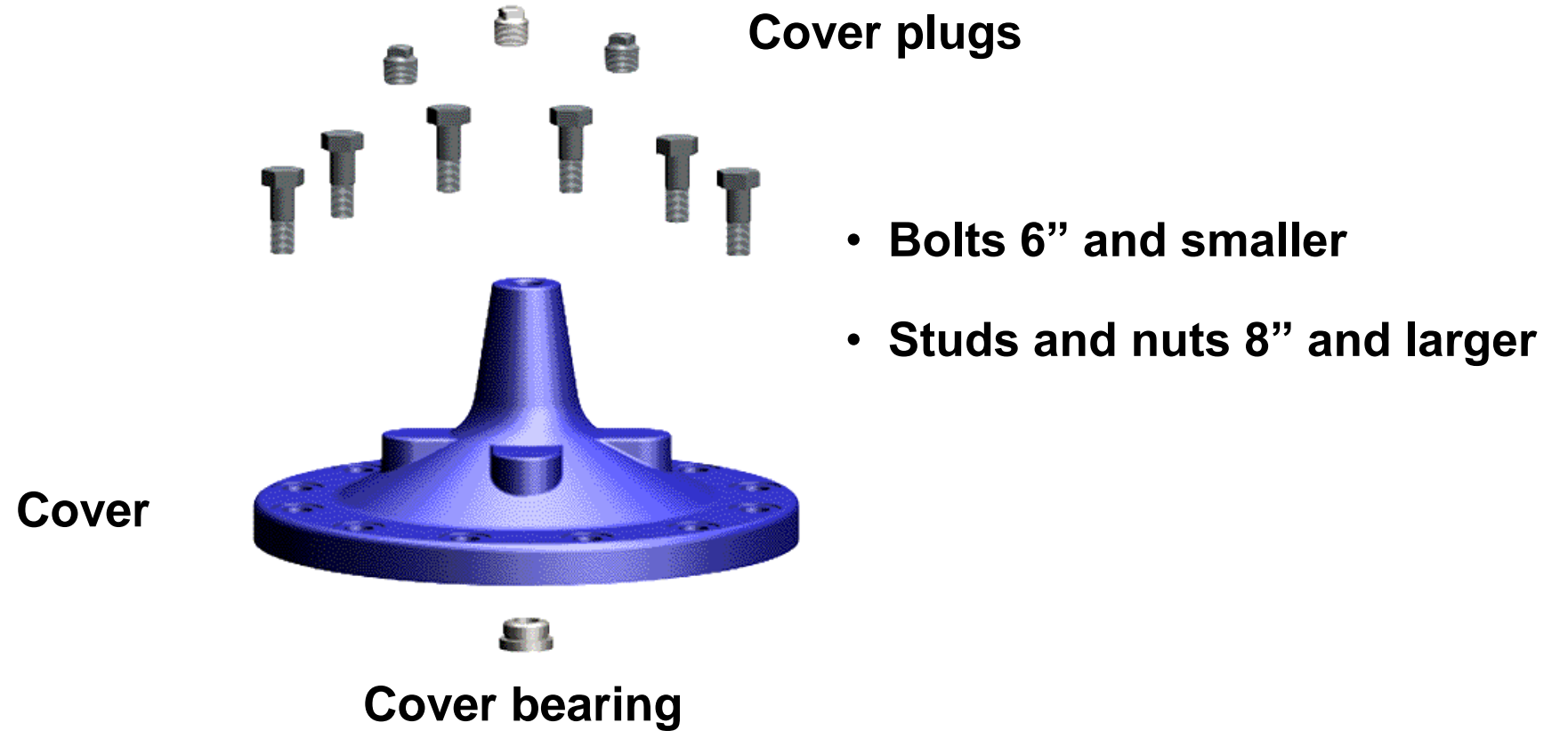

Diaphragm and Disc Assembly

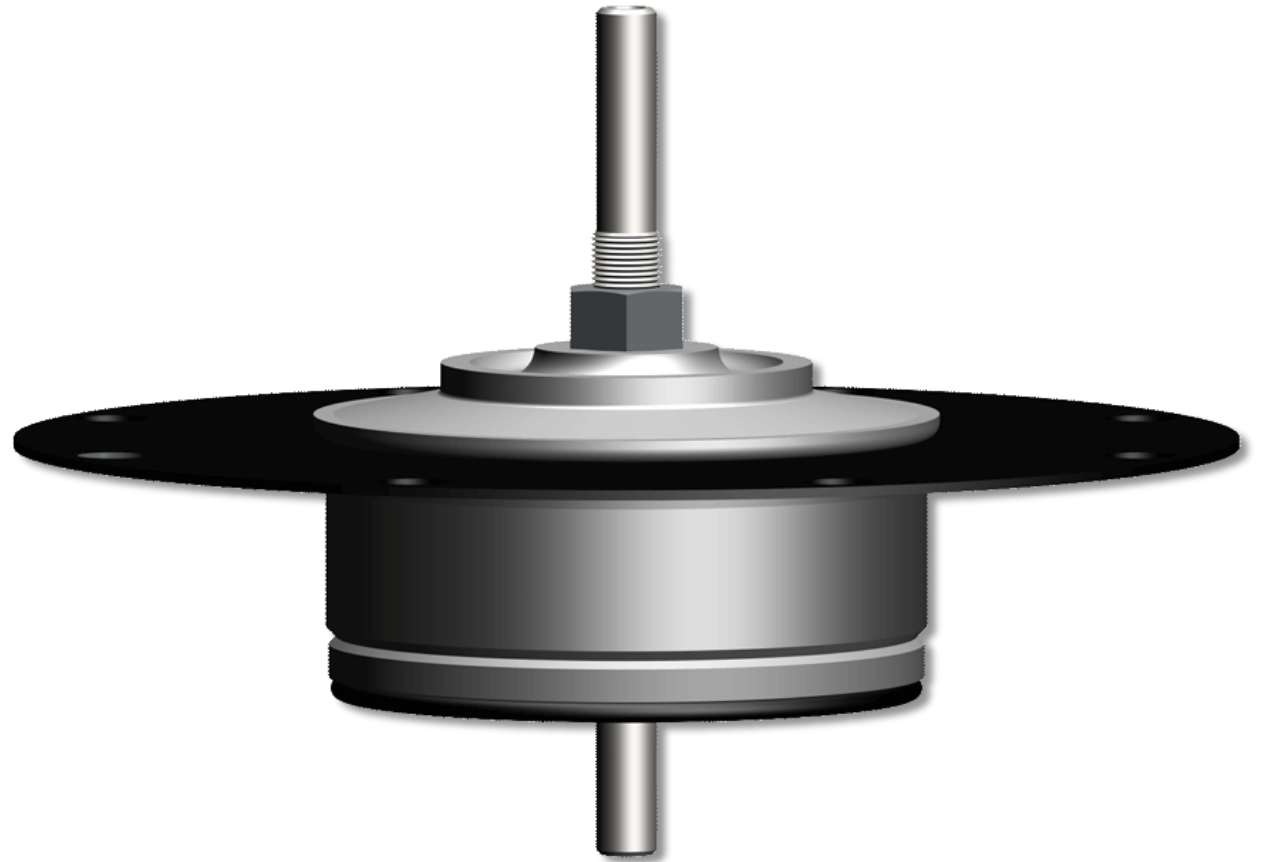

Diaphragm and Disc Assembly

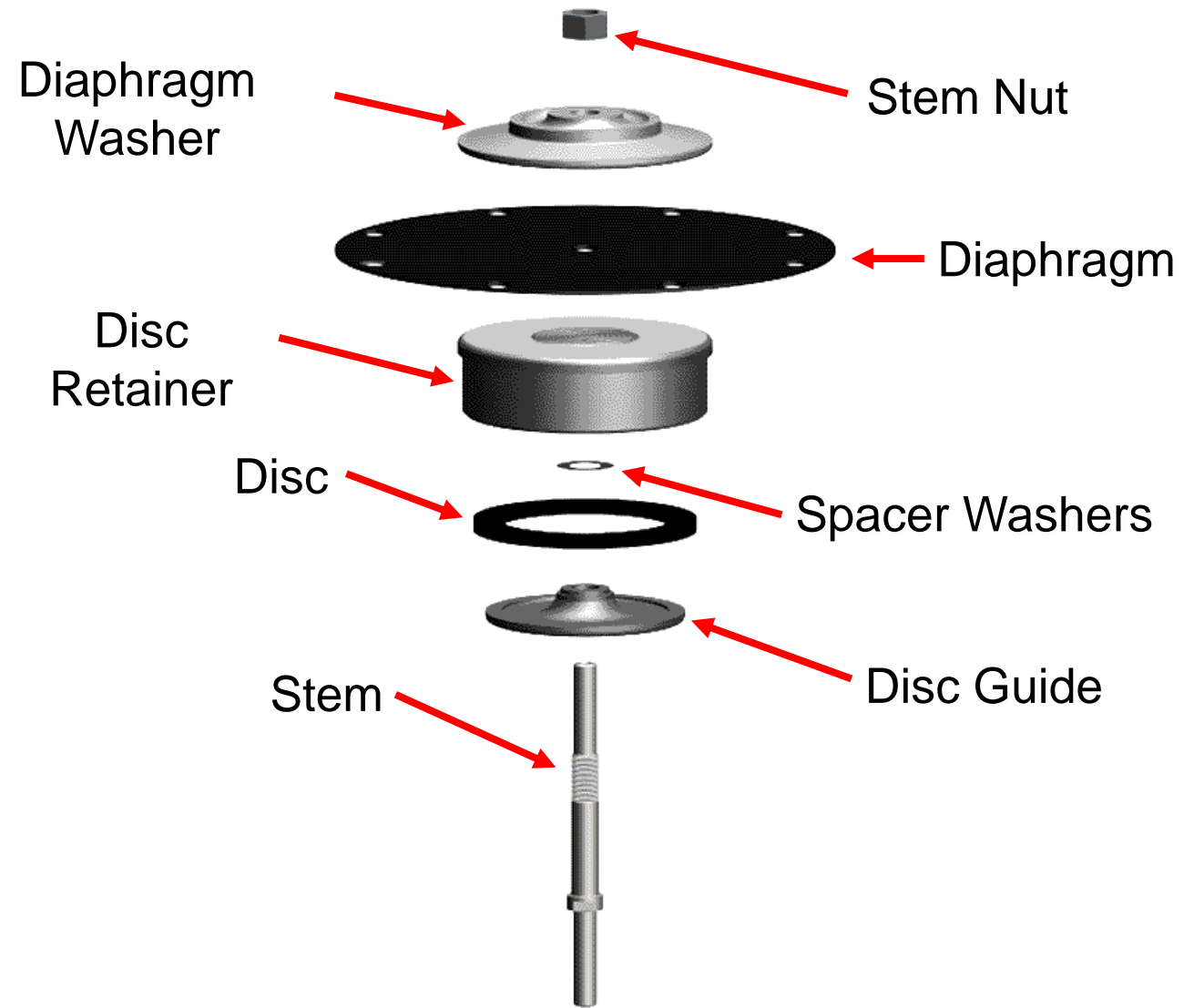

Spring Detail

- Very light and provides a small amount of strength to close the valve on low DP applications
- Helps regain control if/after valve goes full open on a non-modulating valve (full open/close function only)

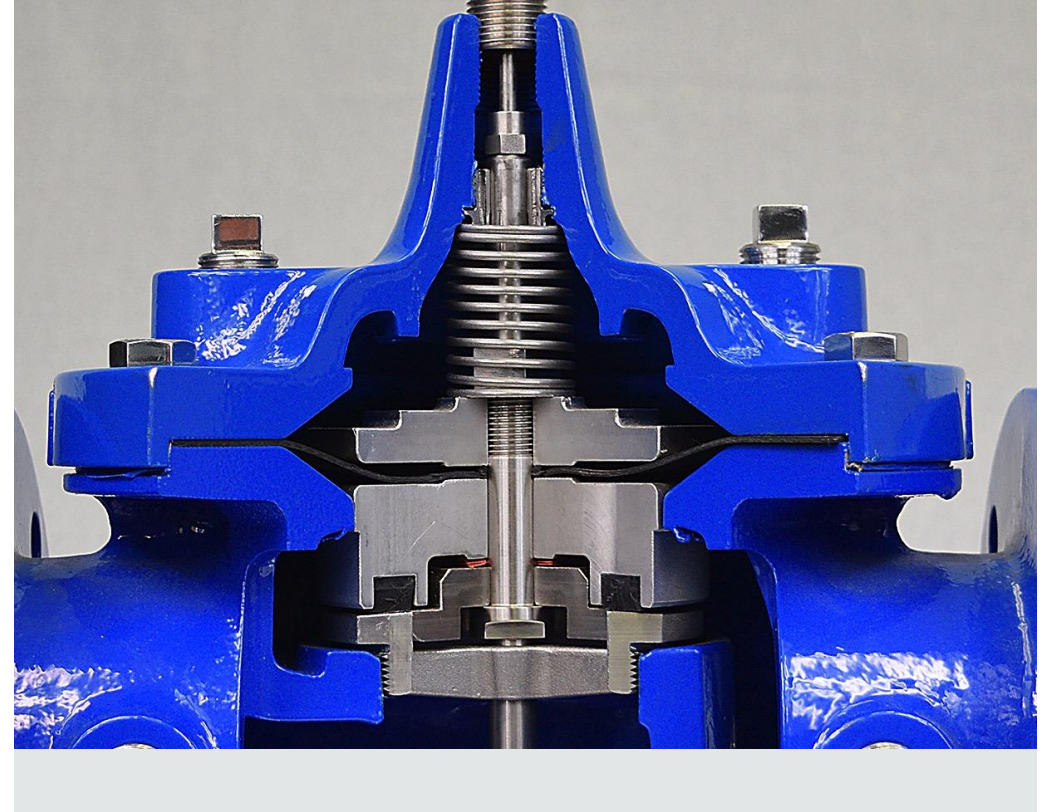

Diaphragm

- Materials
 - Buna-N Rubber
 - Viton
 - EPDM
 - Natural Rubber
- Reinforced with Nylon Layers
- Stamped with Cla-Val Logo & Date



Diaphragm Actuation

Diaphragm seals line pressures
from cover pressure

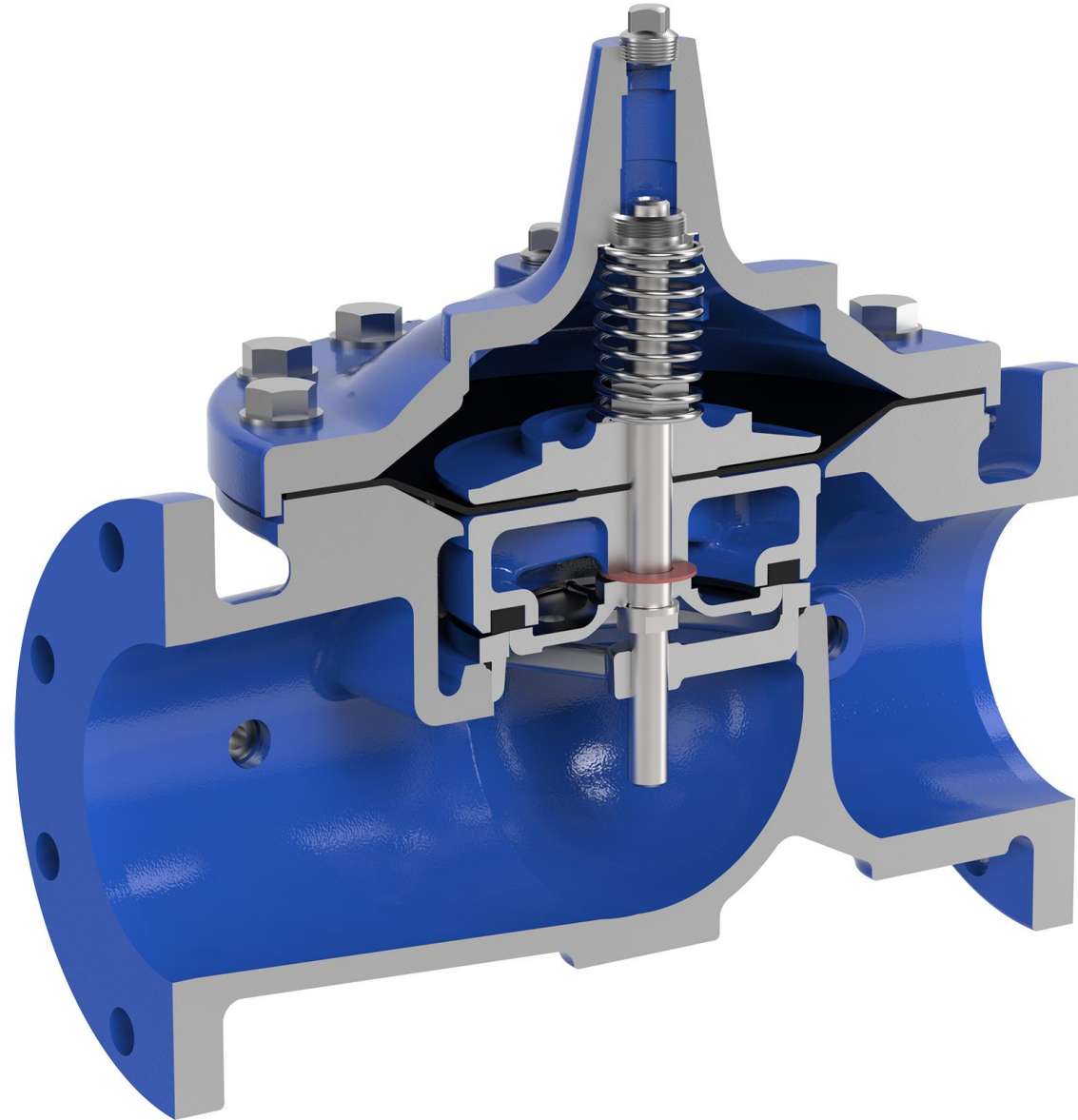

Fully-Supported Diaphragm

Diaphragm seals line pressures from cover pressure

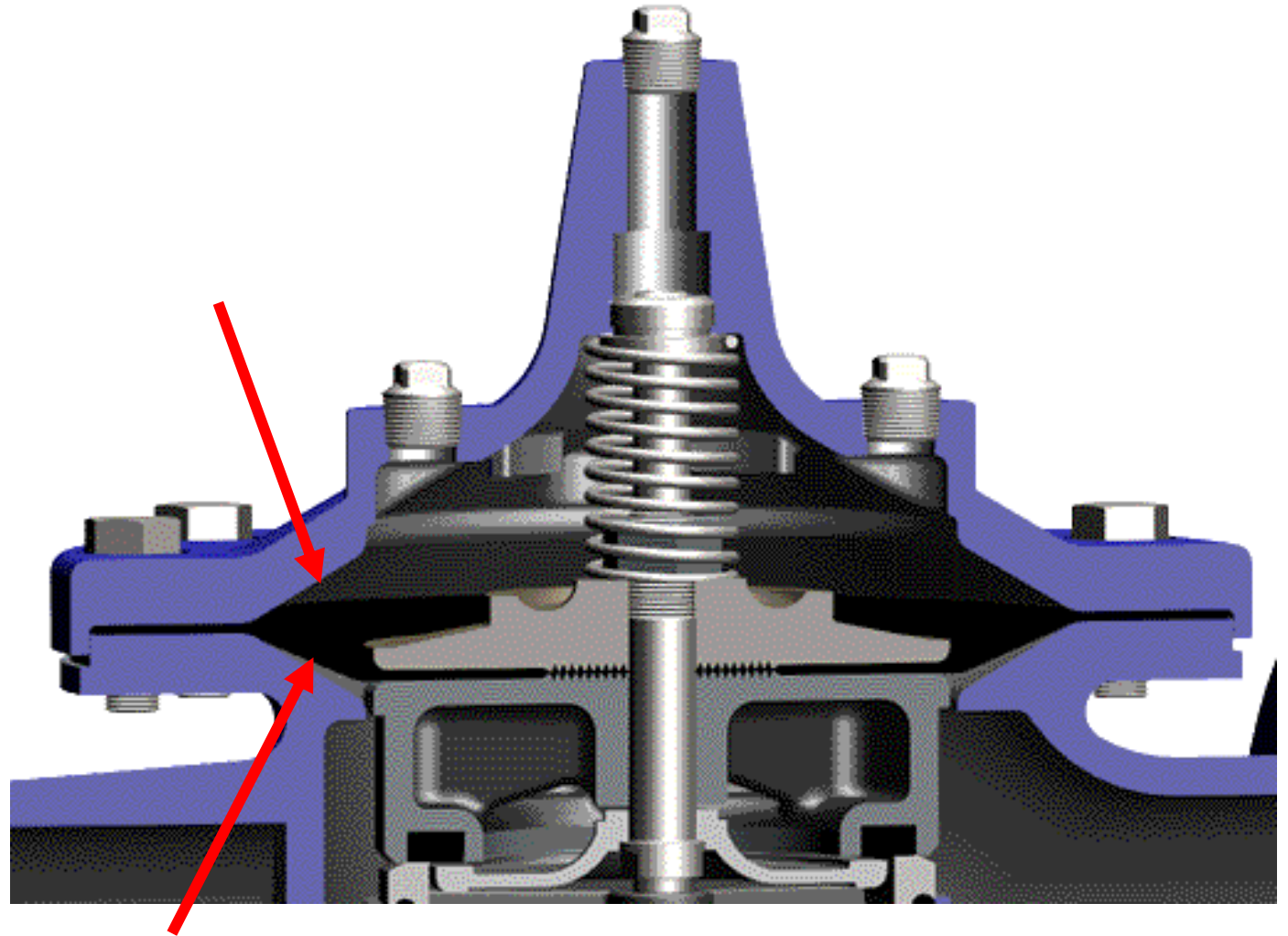

Cover and Body Grips Diaphragm

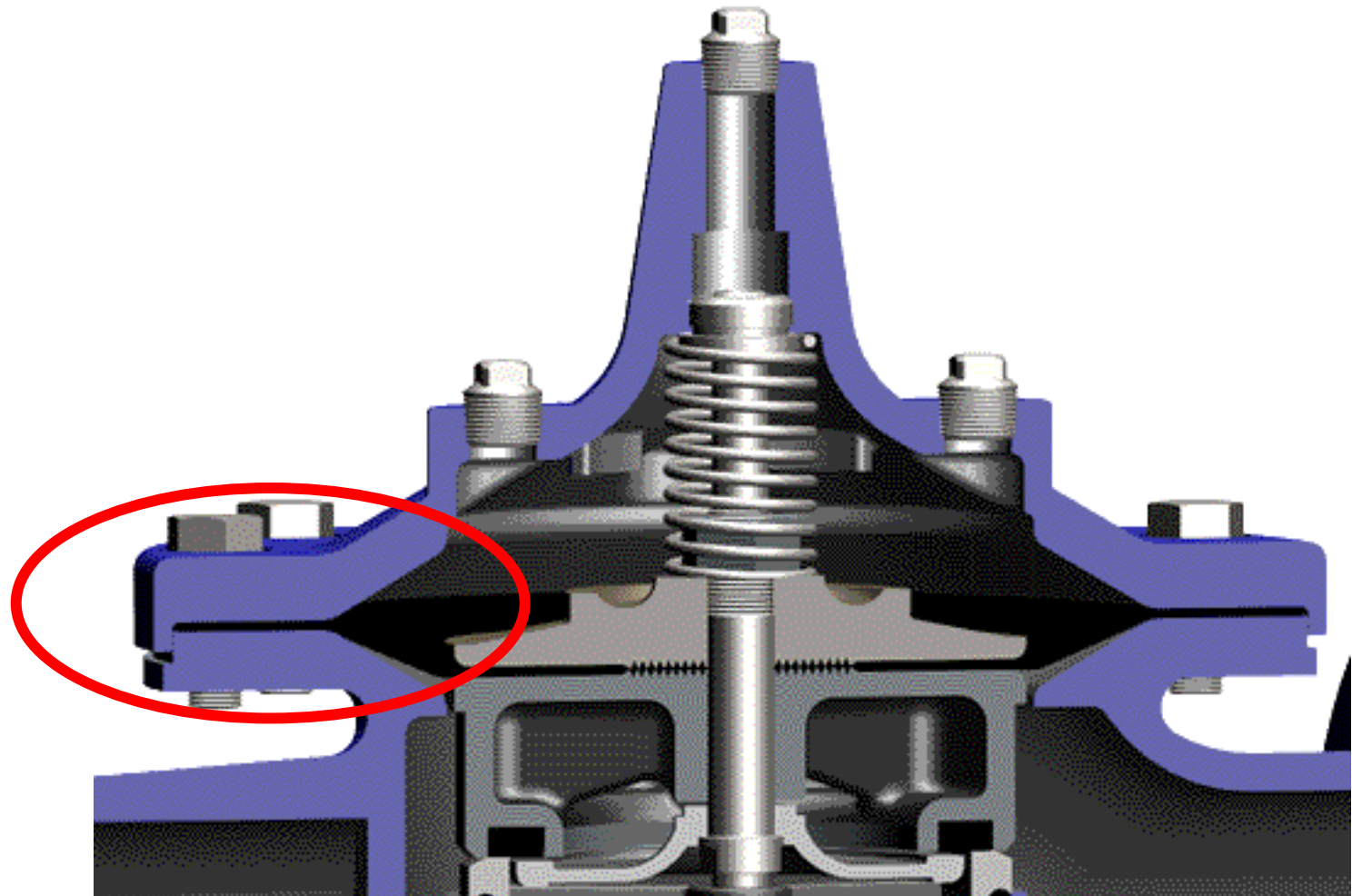

Diaphragm Construction

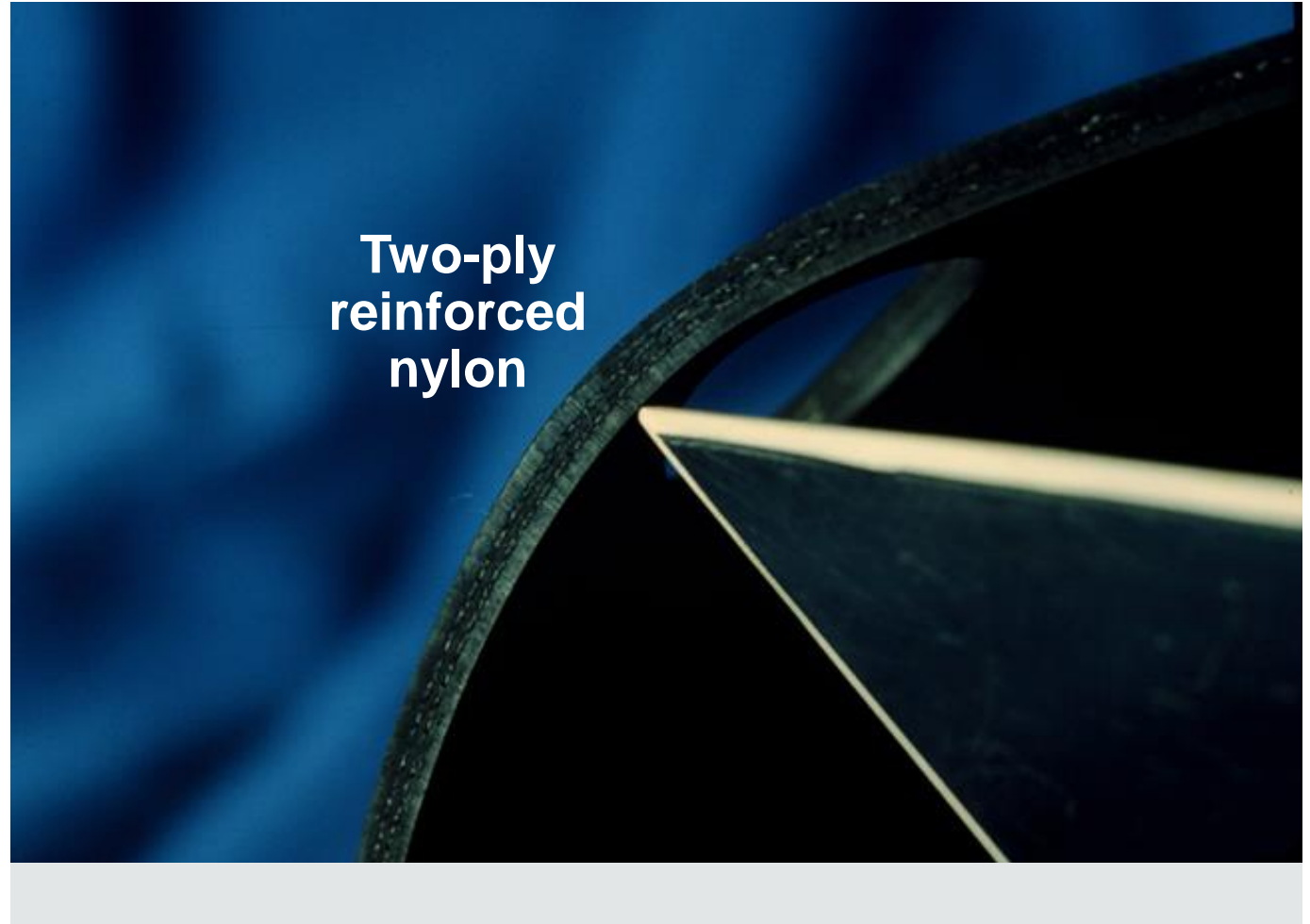

Diaphragm Gripping When Cover is Torqued

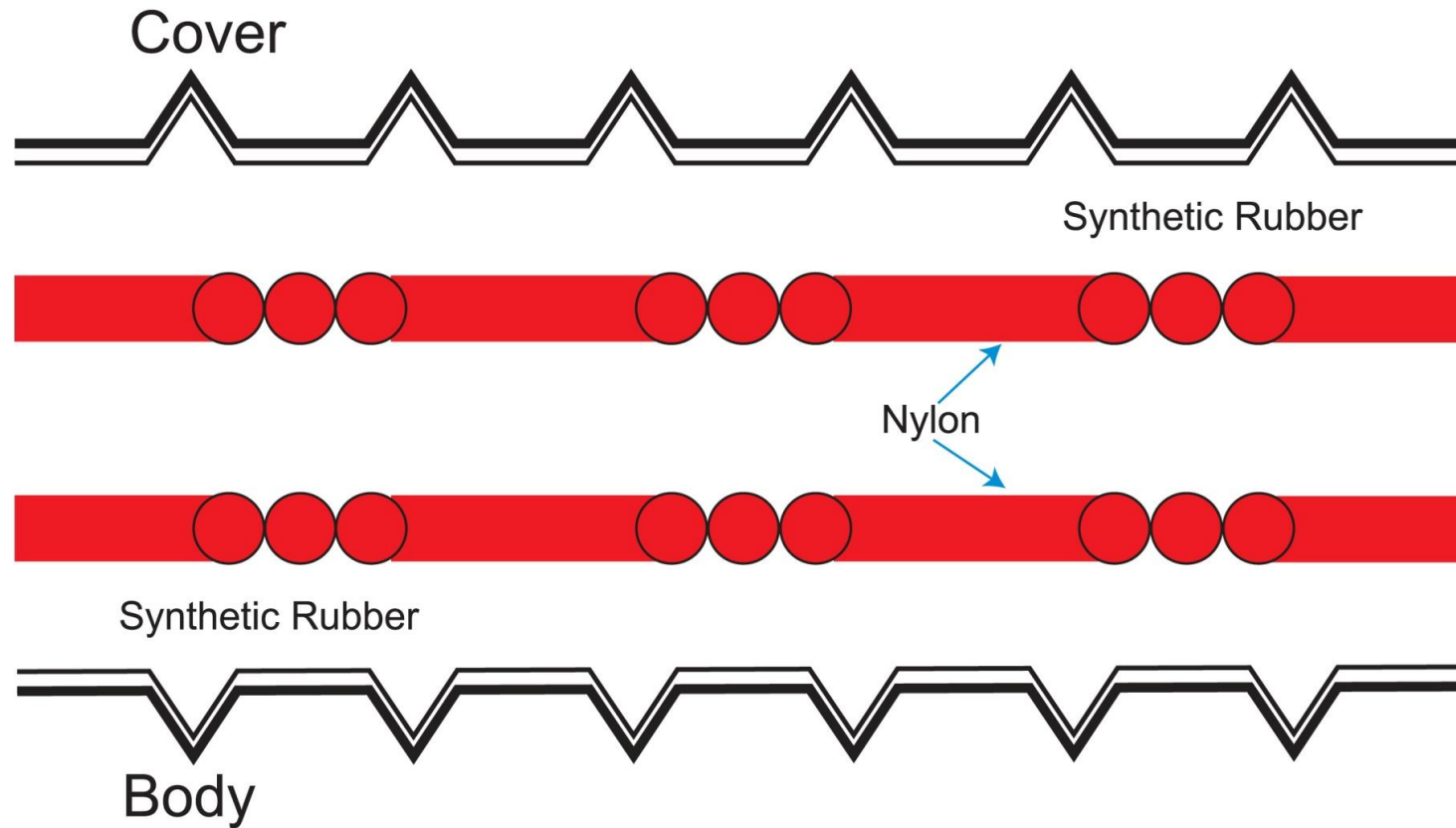

Body & Seat Assembly

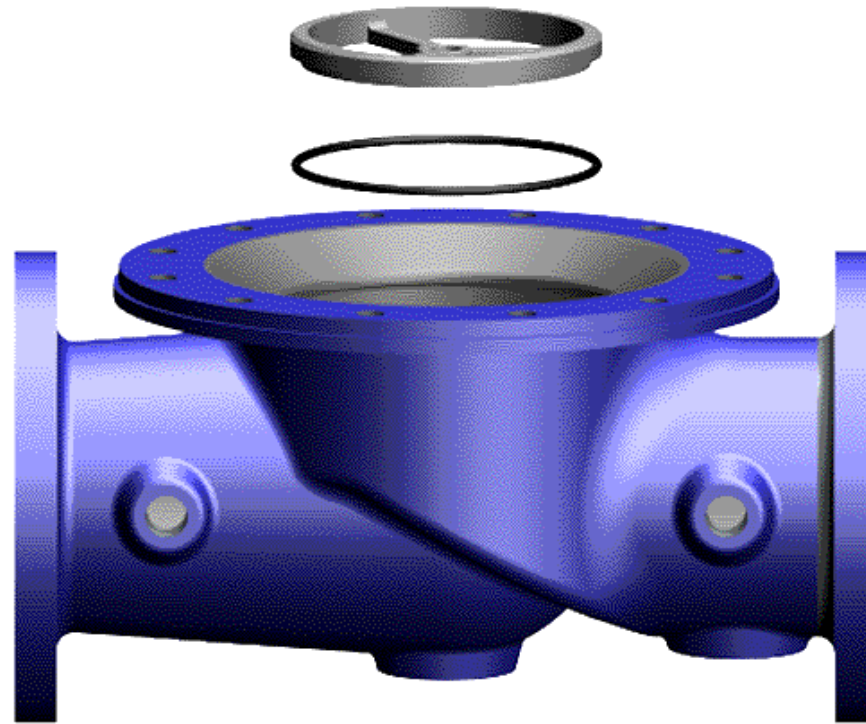

Seat Sealing

No O-Ring

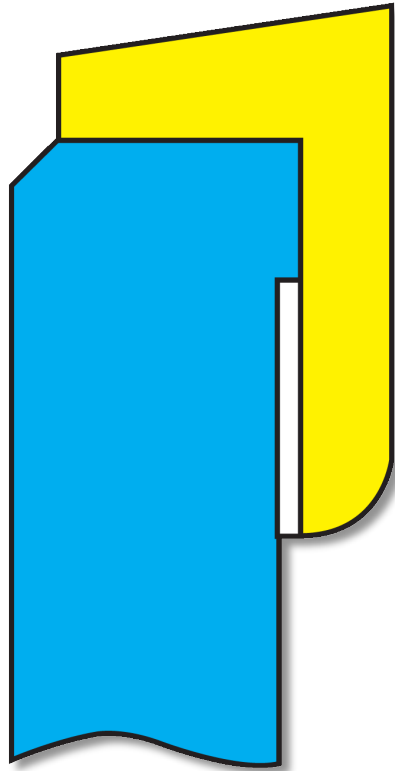

Old Body Style

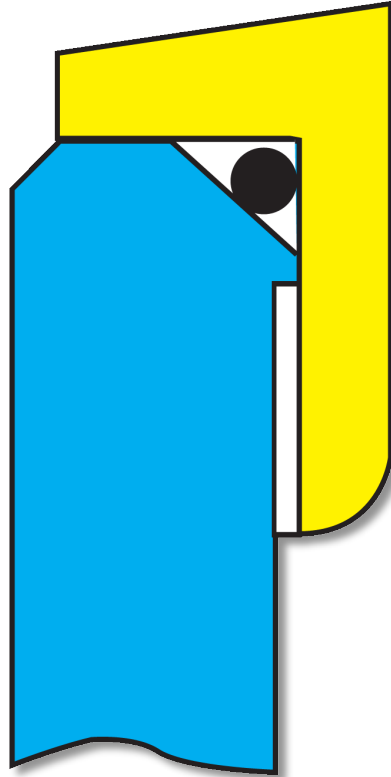

New Body Style

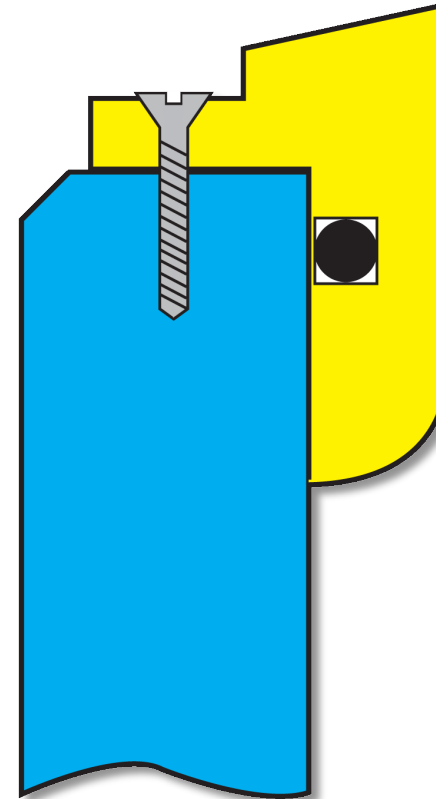

8" & Larger Body

Renewable Seat

- 3/8" to 3/4" Machined (Non Renewable)
- 1" to 6" Threaded
- 8" and larger Seat Screws
- Materials
 - Bronze (Standard)
 - Stainless Steel
 - Monel
- Intended for Lifetime Service
 - Special tool for removal



Seat Design Features

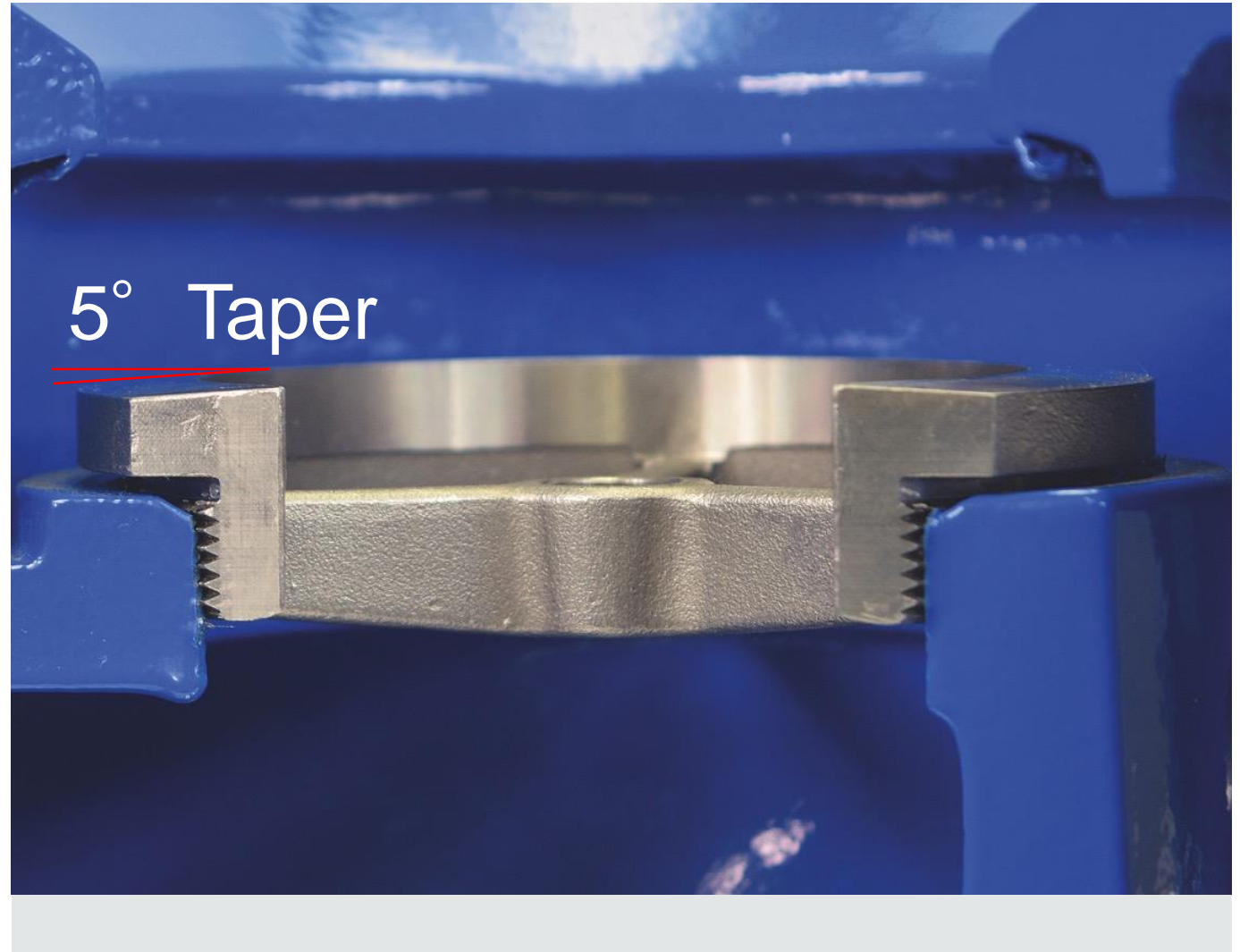

Drip Tight Sealing

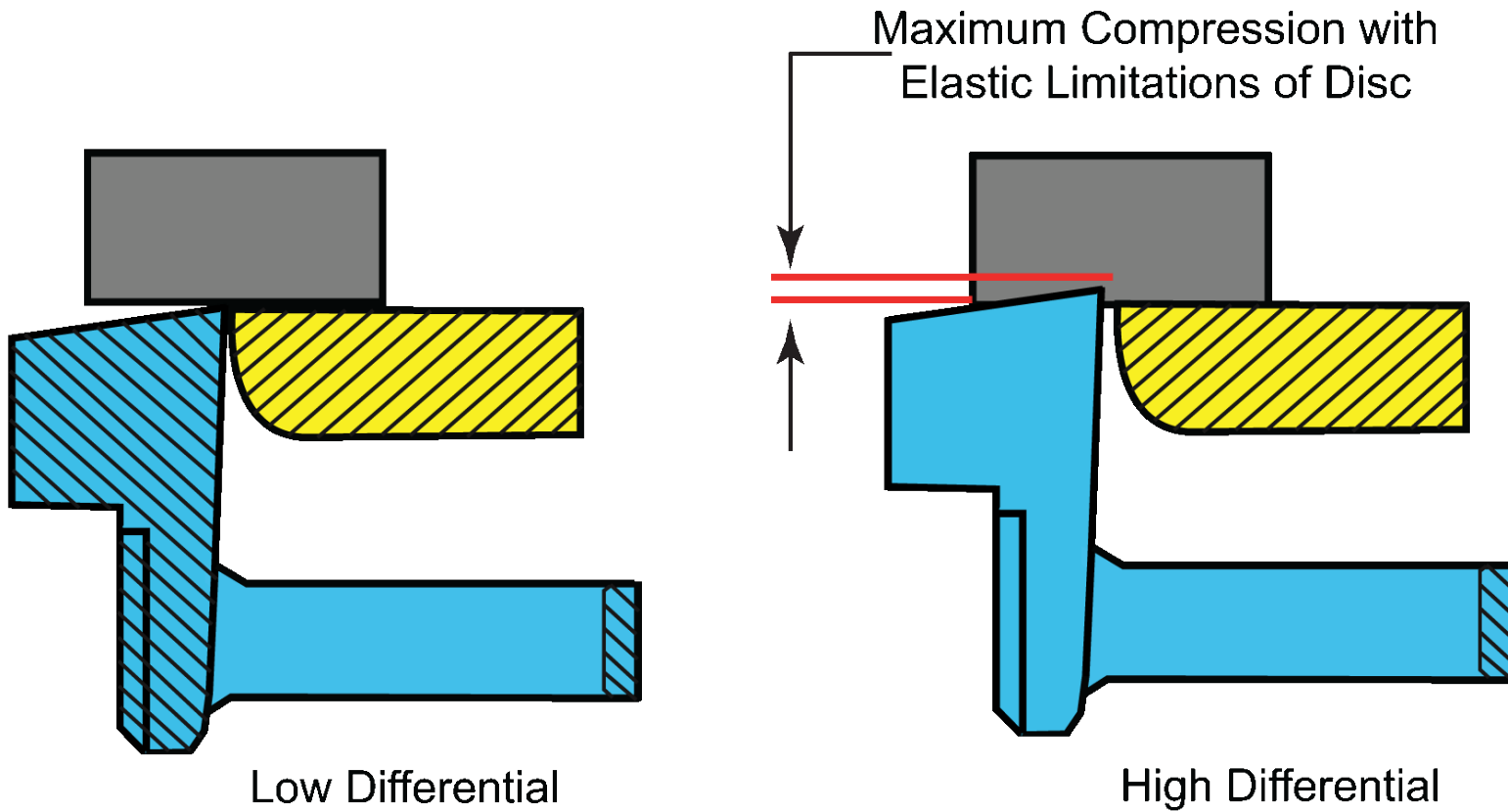

Stem Designs

- Stainless Steel Material
- Allows for accurate alignment of disc to seat
- Creates smooth action
- Assembly stacks up on collar

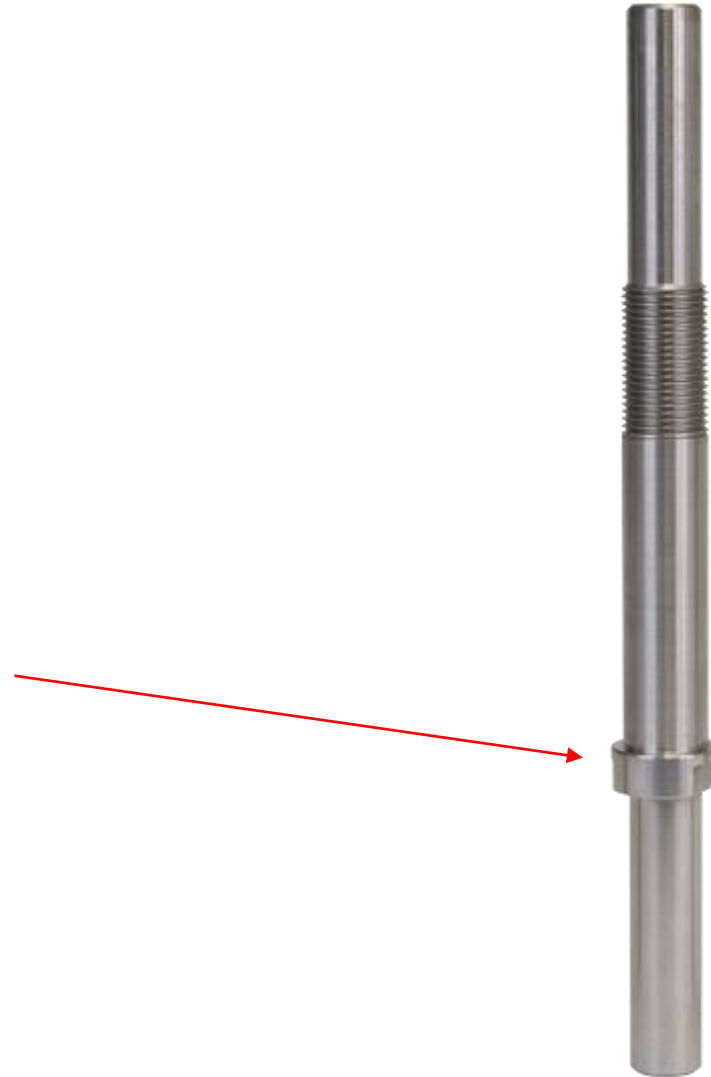

**Dura-Kleen
Stem**

Stem Designs

When tightening stem nut, clamp down only of the provided flat surface of the collar!

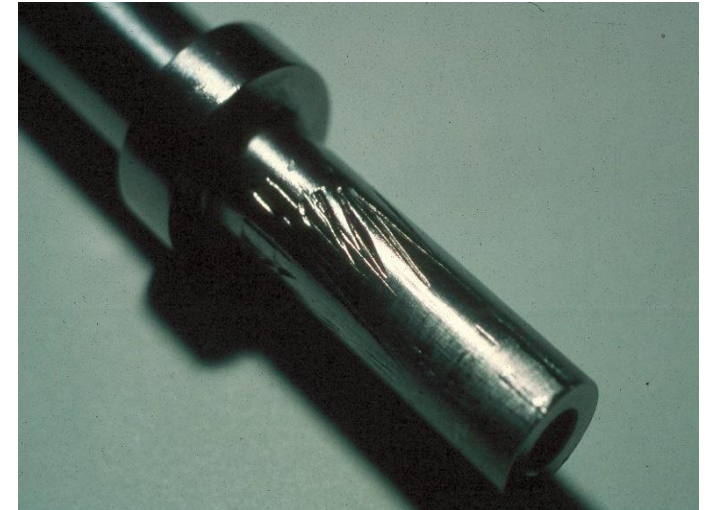
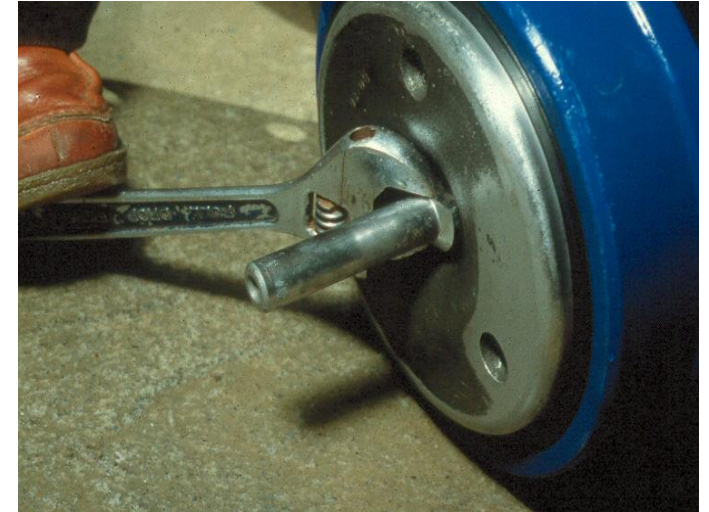

Top and Bottom Guided Stem

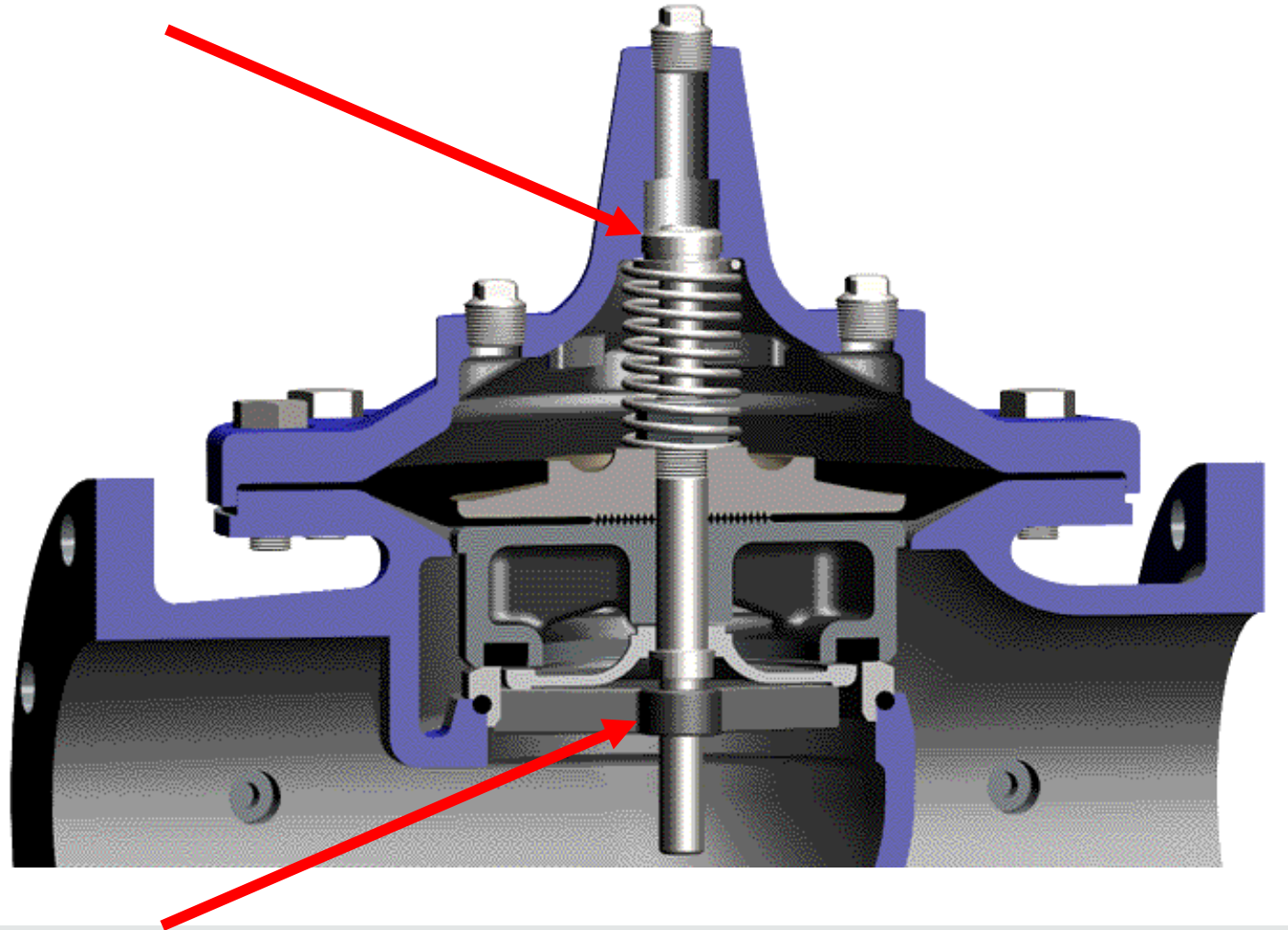

Disc Guide

- Sits 1st on top of the stem collar
- Smooth outer edge referred to as “throttling skirt” for improved flow control at near closed positions
- Holds half of the bottom of the disc in place (so it doesn’t blow out)
- Made in same material as seat
 - Bronze or Stainless Steel



Spacer Washers

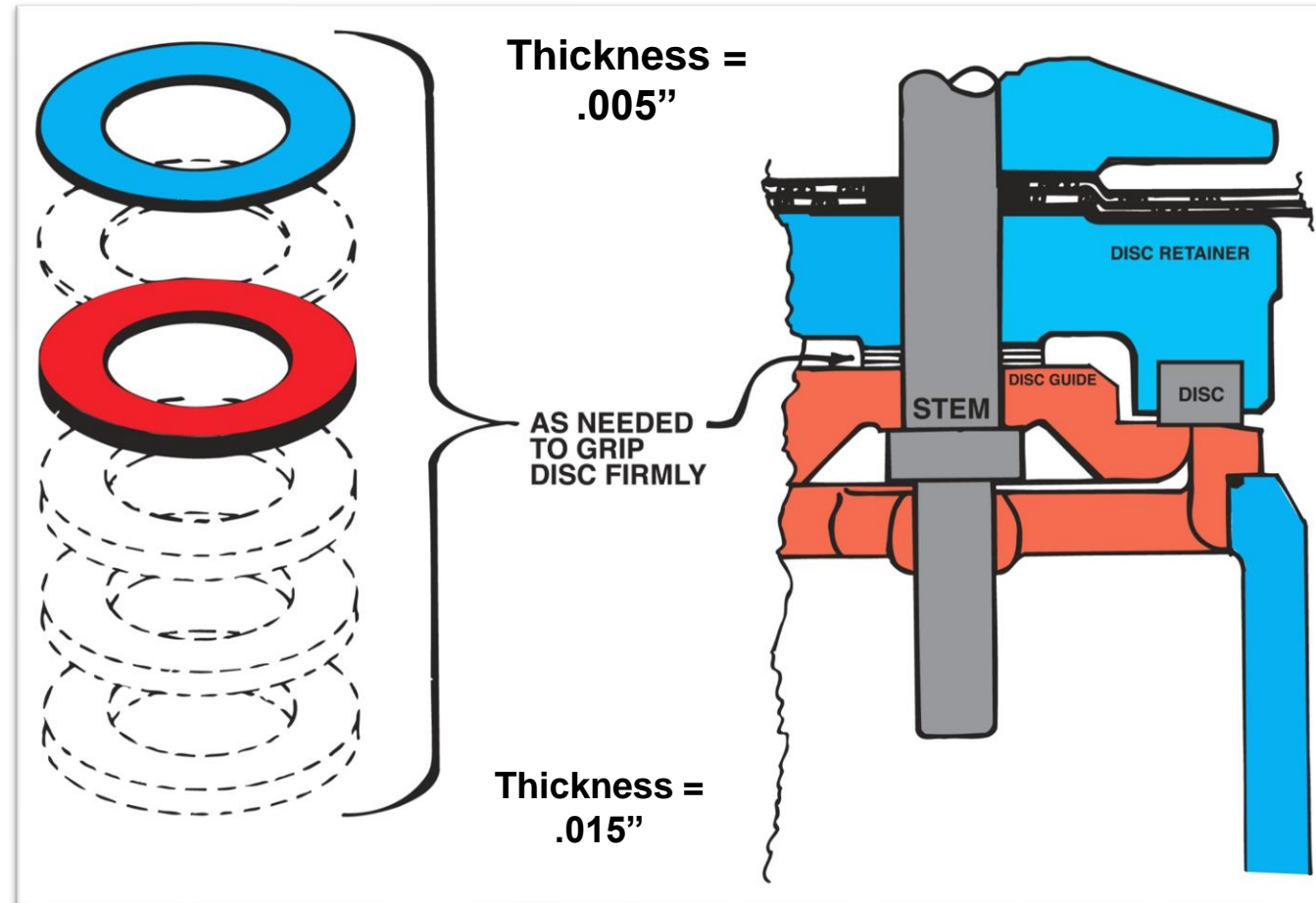

Spacer Washers



Spacer Washers

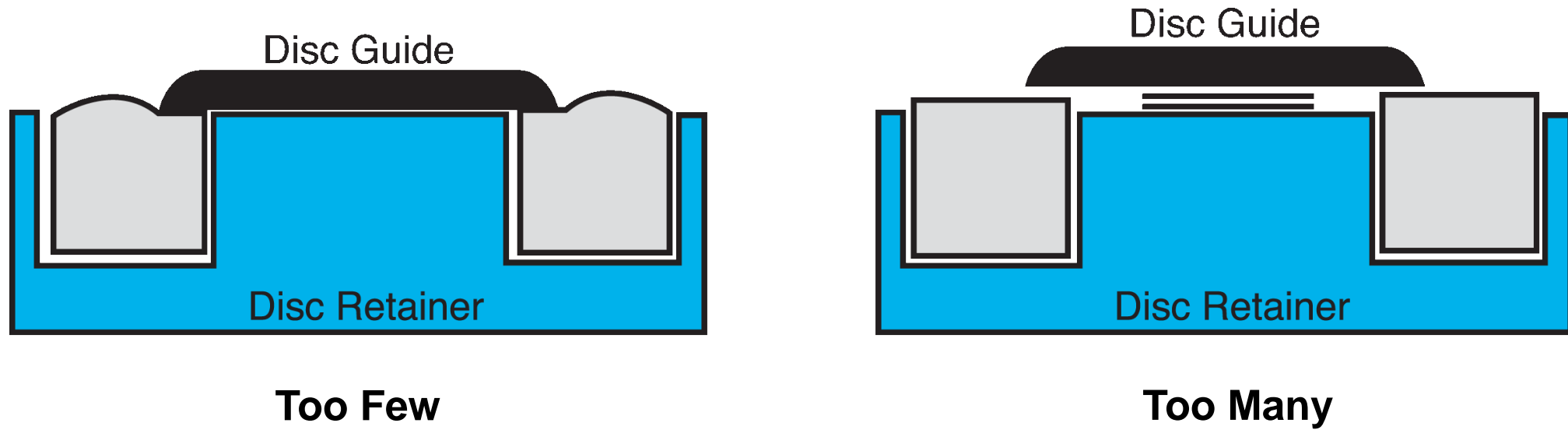

Grip disc firmly without noticeable compression!

When replacing, only replace the outer 2

Blown out disc

Too many washers



Disc and Disc Retainer

- Disc is the main sealing component
 - Buna-N Synthetic Rubber
 - Viton available for special applications
- Retainer holds the disc in place to make even contact with the seat and provides strength to the stack up

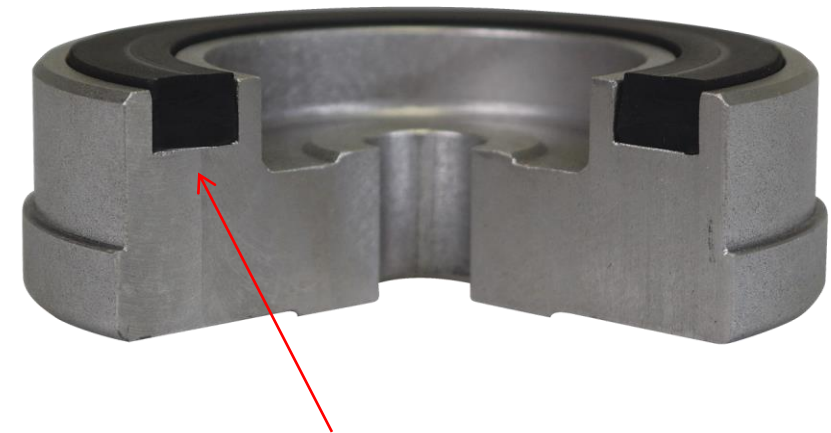

**Retains disc
on 3 sides**



Disc and Diaphragm Storage

Avoid: Light, Heat and Air



New (but old) Diaphragm

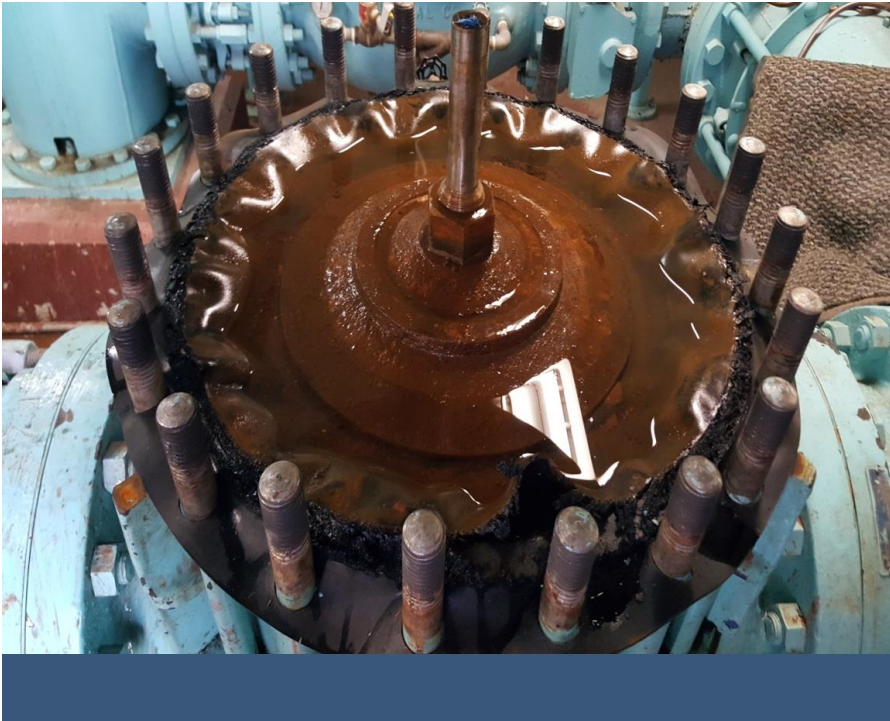

**Lasted 15 minutes in the system
Was stored in direct sunlight**

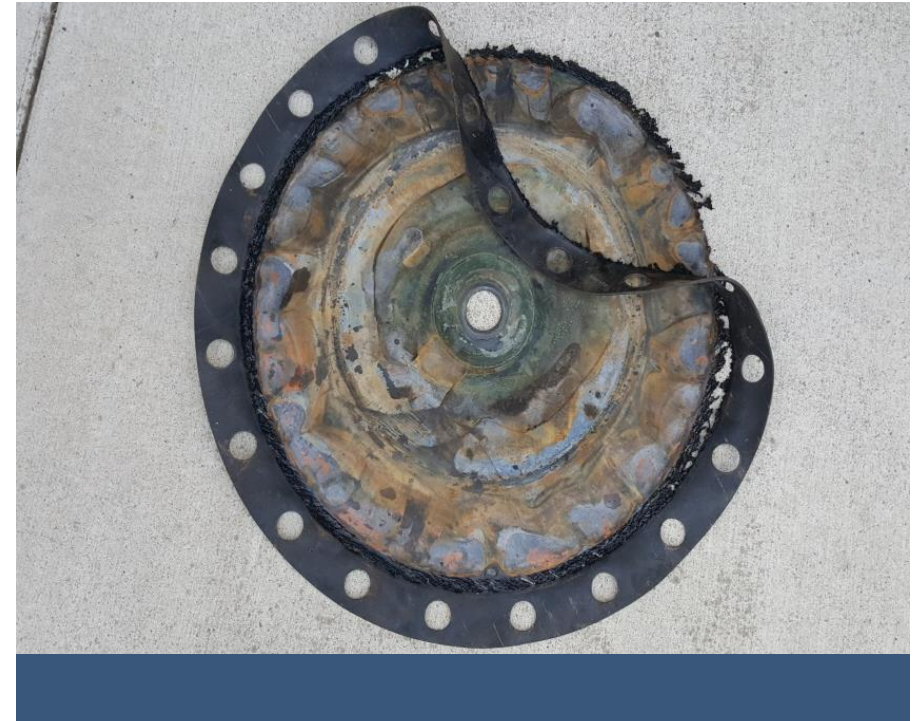

Secure Your Diaphragm

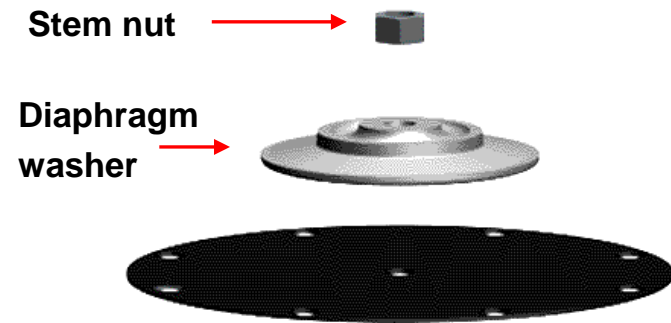

Lock it up



Diaphragm "whipped" – stem nut was not tight enough!

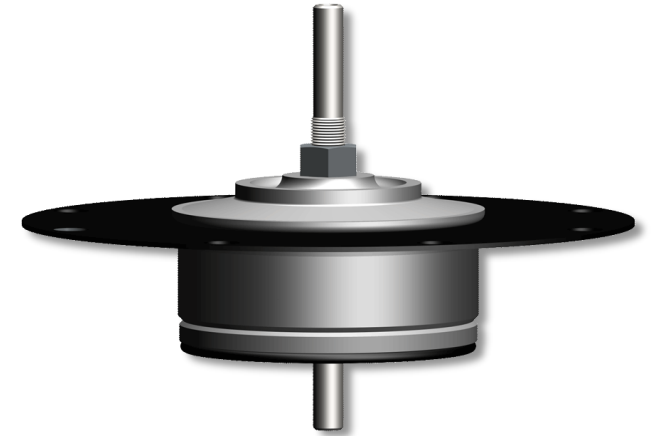

All back together



100-01 Hytrol Main Valve
ASTM A536 Ductile Iron Body
Epoxy Coated
SST Trim Parts List

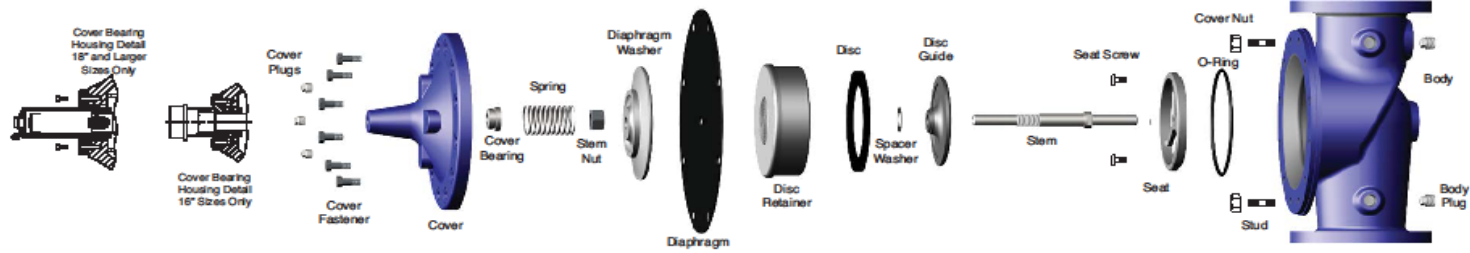

Valve Size	3/8"	1/2"	3/4"	1"	1	1 1/4	1 1/2	2	2 1/2	3	4	6	8	10	12	14	16	18	20	24	
Screwed	100-01-203H	100-01-1072F	100-01-1080J	100-01-1094K	20724403E	100-01-175H	100-01-211A	100-01-185G	100-01-186E	100-01-689K	—	—	—	—	—	—	—	—	—	—	
Ranged	—	—	—	—	—	—	100-01-352C	100-01-275F	100-01-520E	100-01-300B	100-01-166G	100-01-158D	100-01-165J	100-01-181F	100-01-219D	100-01-277B	100-01-243D	20757506A	20668704K	20335708B	
Cover Fastener	6757821 B (8)	6757821 B (8)	6757821 B (8)	6760394 E (8)	6760494 C (8)	6760494 C (8)	6760494 C (8)	6760597 C (8)	6760667 D (8)	6760796 A (8)	6760940 E (8)	6781118 C (12)	—	—	—	—	—	—	—	—	
Cover Bearing	—	—	—	—	C7683A	C7683A	C7683A	C8469D	2804201J	2804201J	2804301G	C0974A	C7414A	C8611A	C8682B	C8682B	1397601 E	2572403A	2572403A	2572402C	
Cover Bearing Bolt	—	—	—	—	—	—	—	—	—	—	—	—	—	—	—	—	6760551 K (8)	760753B (8)	760753B (8)	760753B (8)	
Cover Bearing Gasket	—	—	—	—	—	—	—	—	—	—	—	—	—	—	—	—	V670001 G	00332G	00832G	01121 D	
Cover	C0090F	C6034H	C6034H	6964401 B	9612501 J	7079501 J	7079501 J	7052501 K	7078401 C	7082701 K	7083101 B	7084901 D	7093101 K	70944401 C	7104001 J	7106401 J	7109202 H	20770401 K	20695701 F	2634307 K	
Cover Spring	67362E	C3996D	C3996D	V6134A	C8477G	C8477G	C8477G	C3147A	C3148J	C3149G	C1533D	C1534B	C7948H	C9113G	C9516A	30104E	30104E	20668301 G	20668302 F	2577701 C	
Stem Nut	—	6780206G	6780206G	6780207E	8937501 J	8937501 J	8937501 J	8937601 G	8937701 E	8937701 E	8937801 C	8937901 A	8938001 J	2582501 H	2592601 F	2592601 F	C4832G	20670001 F	20670001 F	2577201 D	
Diaphragm Washer	V1682F	C0082C	C0082C	V6124B	20059301 J	20059301 J	20059301 J	2936301 H	7078601 H	7082901 F	7084201 J	6935701 A	7093902 A	7094801 D	7104201 E	7106601 D	7109301 H	20770601 H	20695901 D	2634501 H	
Diaphragm	61877H	C7548F	C7548F	C2141E	83239E	83239E	83239E	80522G	83240C	83241A	88807F	87893E	11359H	V5576D	V5544B	V1767C	V5591C	20758301 F	2068501 E	2572701 H	
Disc Retainer	30856K	C8939F	C8939F	30578K	C1862G	C1862G	C1862G	C0547E	7078701 F	7083001 D	7084301 G	6935801 J	7093701 G	7094801 H	7104301 C	7106701 B	7109401 F	20770501 J	20695801 E	2634601 F	
Disc	—	—	—	—	V5562D	V5562D	V5562D	V5564K	V1637H	V1734C	V5467F	V1692C	V5566E	V5569J	V5541H	V1766E	V1689J	20758501 D	20668001 K	1434201 J	
Spacer Washer	—	—	—	—	V5180E	V5180E	V5180E	V5232D	V0631B	V0631B	V0634F (2)	V5138C (2)	V5133D (2)	V5160G (2)	V5131H (2)	V5601 K (2)	V5601 K (2)	20682301 H (2)	20682301 H (2)	2577301 B (4)	
Disc Guide	—	C3971D	C3971D	C4547A	C4547A	C1642C	C1642C	C0546G	V6561E	C1518E	V6573K	V6792F	C1472E	C7957J	C8684H	41179D	43955E	20758202 F	2068402 E	20679102 E	
Stem	—	—	—	—	V1388H	V1388H	V1388H	V5499J	V5433H	V5446K	V5455A	V5519D	V1353B	V1789G	C4047B	C0089H	32686J	20758401 E	20667801 D	2572601 K	
Seat	—	62187A	62187A	C4549G	C1425C	C1425C	C1425C	C4135E	V6662C	C1520A	V6574H	C1029C	C1474A	C7959G	C8686C	41178F	C3907H	20757901 B	20667901 C	2588902 H	
Seat Screw	—	—	—	—	—	—	—	—	—	—	—	—	6797225H (8)	6797225H (10)	6797225H (12)	6797325F (12)	6797326D (12)	2599413J (16)	2599410E (16)	2599410E (16)	
O-Ring, Seat	—	00718H	00718H	00724F	00731A	00731A	00731A	00777D	00785G	00788A	00836H	00851 G	00982K	00865G	00869J	00870G	00999D	00832G	01192E	01121D	
Cover Nuts	6757821 B (8)	6757821 B (8)	6757821 B (8)	—	—	—	—	—	—	—	—	—	678118C (16)	6781418C (20)	6781818H (20)	6782018D (20)	6782018D (20)	6782018D (24)	20681918E (24)	6782518C (24)	
Body Stud	—	—	—	—	—	—	—	—	—	—	—	V6901C (12)	37048G (16)	37041B (20)	V6896E (20)	37042K (20)	37042K (20)	42786E (24)	20681801 (24)	2577801A (24)	
Body (Threaded)	C0091D	9472001 J	85774J	9603301 B	20775501 H	9606307 J	7079201 F	7052601 H	7078001 A	7082501 D	—	—	—	—	—	—	—	—	—	—	
Body (Flanged)	—	—	—	—	—	—	7079301 D	7061501 J	7077501 A	7079601 G	7083501 C	7092601 K	7093301 F	7094001 A	7103701 E	7106205D	7108901 F	2812305H	2069501 G	1996109D	
Body Plug	6766003 F	6784701 C	6784701 C	6786020 K	6786021 H	6786021 H	6786022 F	6786022 F	6786022 F	6786023 D	6786023 D	6786024 B	6786024 B	6786024 B	6786024 B	6786024 B	6786024 B	6786024 B	6786024 B	6786015 K	6786015 K
Diaphragm / Disc Assembly	48097K	C2518D	C2518D	C2520K	14201 J	14201 J	14201 J	2806204 A	2806201 G	74197F	74198D	74199B	74200H	26289K	17267G	20061619B	20061608E	—	—	20061620J	
Repair Kit	9169801 K	9169802 H	9169802 H	9169803 F	9169804 D	9169804 D	9169804 D	9169805 A	9169811 J	9169812 G	9169813 E	9169815 K	9817901 D	9817902 B	9817903 K	9817904 H	9817905 E	—	—	—	
Repair Kit Plus	—	—	—	—	—	—	—	9817907 A	9817908 J	9817909 G	9817910 E	9817911 C	9817912 A	—	—	—	—	—	—	—	
Approx. Ship Wt. Lbs.	3	3	8	8	15	15	15	35	50	70	140	285	500	780	1165	1600	2265	2982	3900	6200	

*Non Guided Stem Auxiliary Hytrol Controls

Diaphragm / Disc Assembly: Diaphragm, Stem Nut, Disc Guide, Spacer Washer, Diaphragm Washer, Stem, Disc Retainer and Disc.

Repair Kit: Diaphragm, Disc and Spacer Washer

Repair Kit Plus: Protective Plastic Washer, Epoxy Coated Diaphragm Washer, Diaphragm, Epoxy Coated Disc Retainer, Spacer Washers and Disc.

R-04-13

100-01 Parts List

Cla-Val Parts Guide

- Complete list of valve and pilot parts
- Stop by our booth this week to grab a copy!



Service Kit Type	Diaphragm	Spacer Washers	Disc (or Disc Assembly)	Stainless Steel Bolts and Washers		Epoxy Coated Disc Retainer		Protective Washer	Stem	Stainless Steel Disc Guide	Stem Nut	Standard Cover Spring	Cover Washer
				6" & BELOW	8" & ABOVE	Epoxy Coated Disc Retainer	Epoxy Coated Diaphragm Washer						
Rubber	✓	✓	✓	✗	✗	✗	✗	✗	✗	✗	✗	✗	✗
Repair Kit	✓	✓	✓	✗	✗	✓	✓	✓	✗	✗	✗	✗	✗
Rebuild Assembly	✓	✓	✓	✓	✓	✓	✓	✓	✓	✓	✓	✓	✓
Stud & Nut Kit	✗	✗	✗	✓	✓	✗	✗	✗	✗	✗	✗	✗	✗



REPAIR KITS & PARTS LISTS
Main & Pilot Control Valves

Cla-Val Nameplate Locations

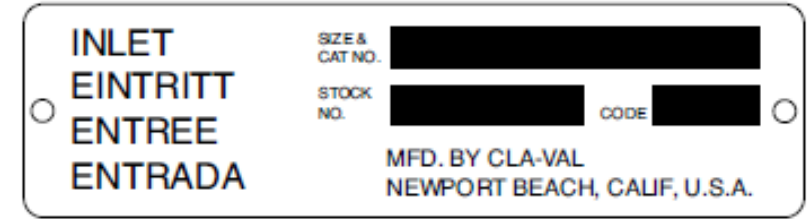

2-1/2" and larger flanged valves

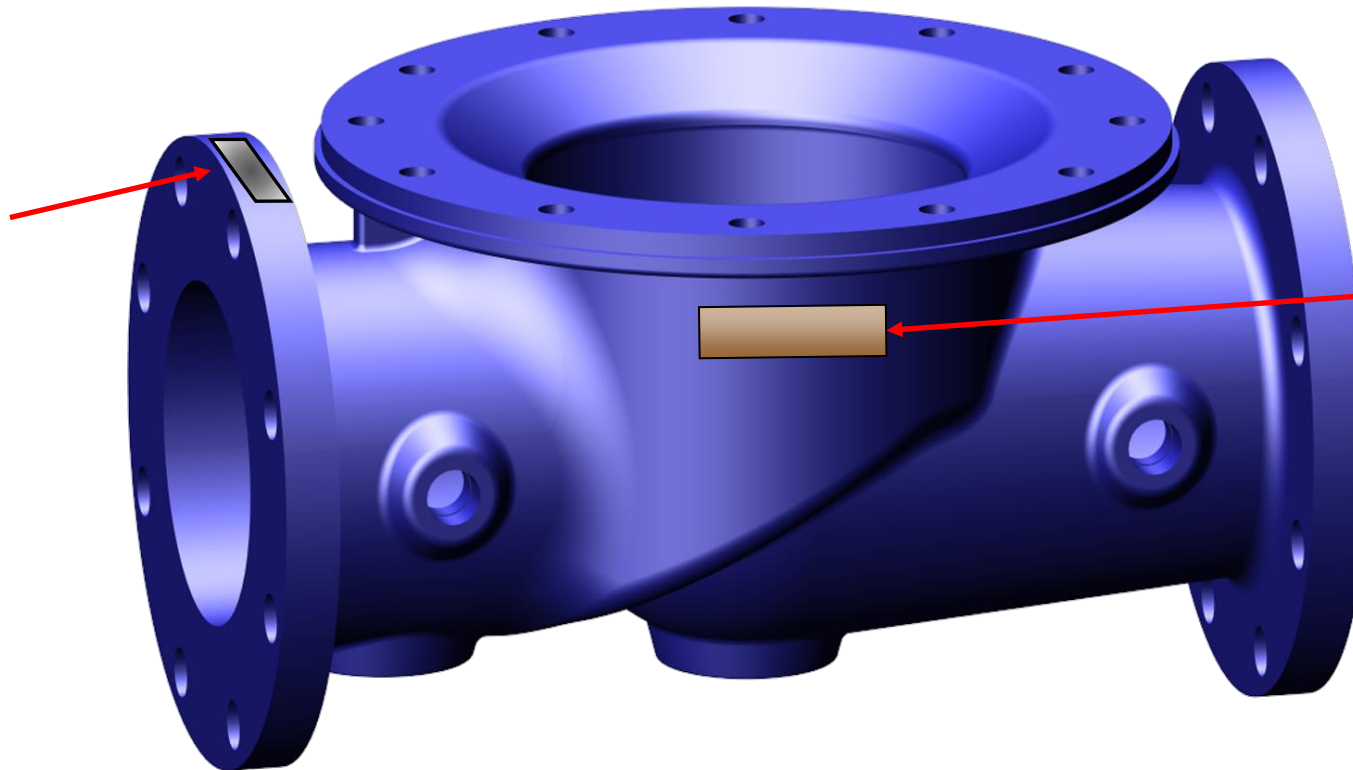

2" and smaller flanged valves and all threaded and grooved valves

Can you read this nameplate?



Record the information before the tag looks like this!

Link-2-Valves

- A simple to use tool to manage the service scheduling of your automatic control valves.
- Works on Desktop and Mobile App
- Secure

 **Link2Valves™**
Simplified Control Valve Service Management



Catalog Numbering System

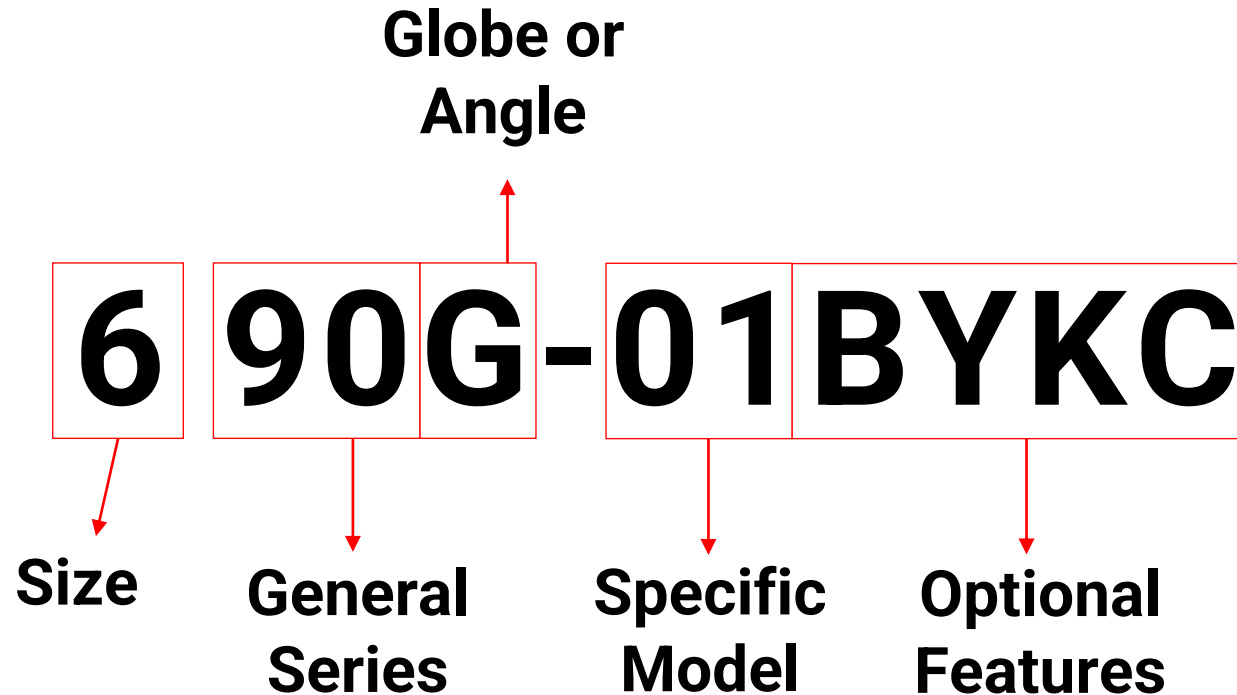

Model Numbers

6" **90**G-**01**BYKC

Model numbers are based on application category

Thousands of specific models in each category

APPLICATION CATEGORIES	SERIES
Rate of Flow (Flow Limiting)	40 - 49
Pressure Relief/Sustaining	50 - 59
Pump Control (Booster/Deep Well)	60 - 69
Check	80 - 89
Pressure Reducing	90 - 99
Float (Modulating & Non-Modulating)	120 - 129
Solenoid /Electronic & Metering	130 - 139
Altitude (Level Control)	206 - 210
Differential Relief	250 - 259
Float (Modulating Only)	420 - 429

Optional Features

6" 90G-01BYKC

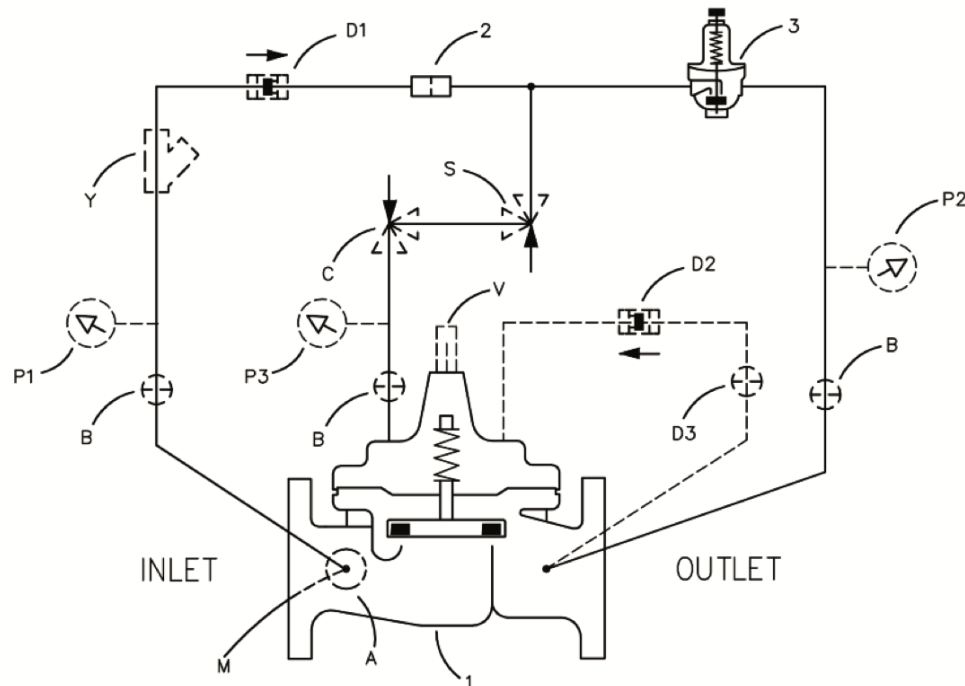

Schematic Diagram

Item	Description
1	100-01 Hytrol Main Valve
2	X58 Restriction Fitting
3	CRD Pressure Reducing Control

Optional Features

Item	Description
A	X46A Flow Clean Strainer
B	CK2 Isolation Valve
C	CV Flow Control (Closing)*
D	Check Valves with Isolation Valve
M	X144 e-FlowMeter
P	X141 Pressure Gauge
S	CV Flow Control (Opening)
V	X101 Valve Position Indicator
Y	X43 "Y" Strainer

*The closing speed control (optional) on this valve should always be open at least three (3) turns off its seat.

Optional Features

6" 90G-01 **BYKC**

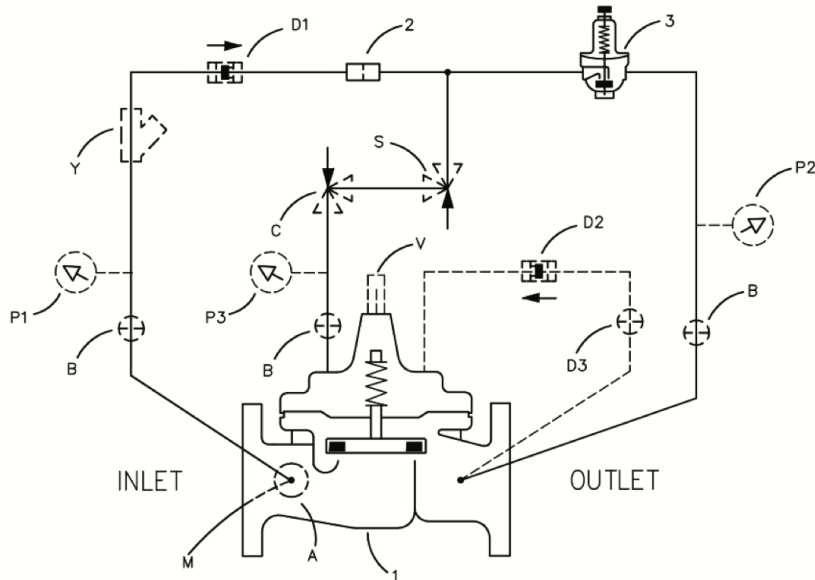

SUFFIX / OPTIONS

A	X46 Flow Clean Strainer
Y	X43 "Y" Pattern Strainer
B	CK2 Isolation Valves
F	Independent Operating Pressure
C	CV Closing Speed Control
D	Check Valves with Isolation Valves
E	X117D Valve Position Transmitter
H	Atmospheric Drain
N	VC-22D Electronic Controller
M	X144D Flow Meter
S	CV Opening Speed Control
P	Inlet/Outlet Pressure Gauges
V	X101 Valve Position Indicator
KC	Epoxy Coating (Main Valve)
KD	Dura-Kleen® Stem
KE	Motorized Pilot Valve
KG	Delrin Stem Sleeve
KO	Anti-Cavitation Trim
KR	Reverse Flow (Main Valve)
KB	KB Viton Rubber Parts
X	Extra/Unique, i.e. Adders

Pressure Gauges are Essential

-
- Set Pressure on Start-Up
 - Troubleshooting
 - Field Adjustments
 - Record Keeping & Maintenance



Use the appropriate gauge for your system's pressures



**Would you use this for
Outlet Pressure of 75psi?**



**Would you use this for
Outlet Pressure of 15psi?**

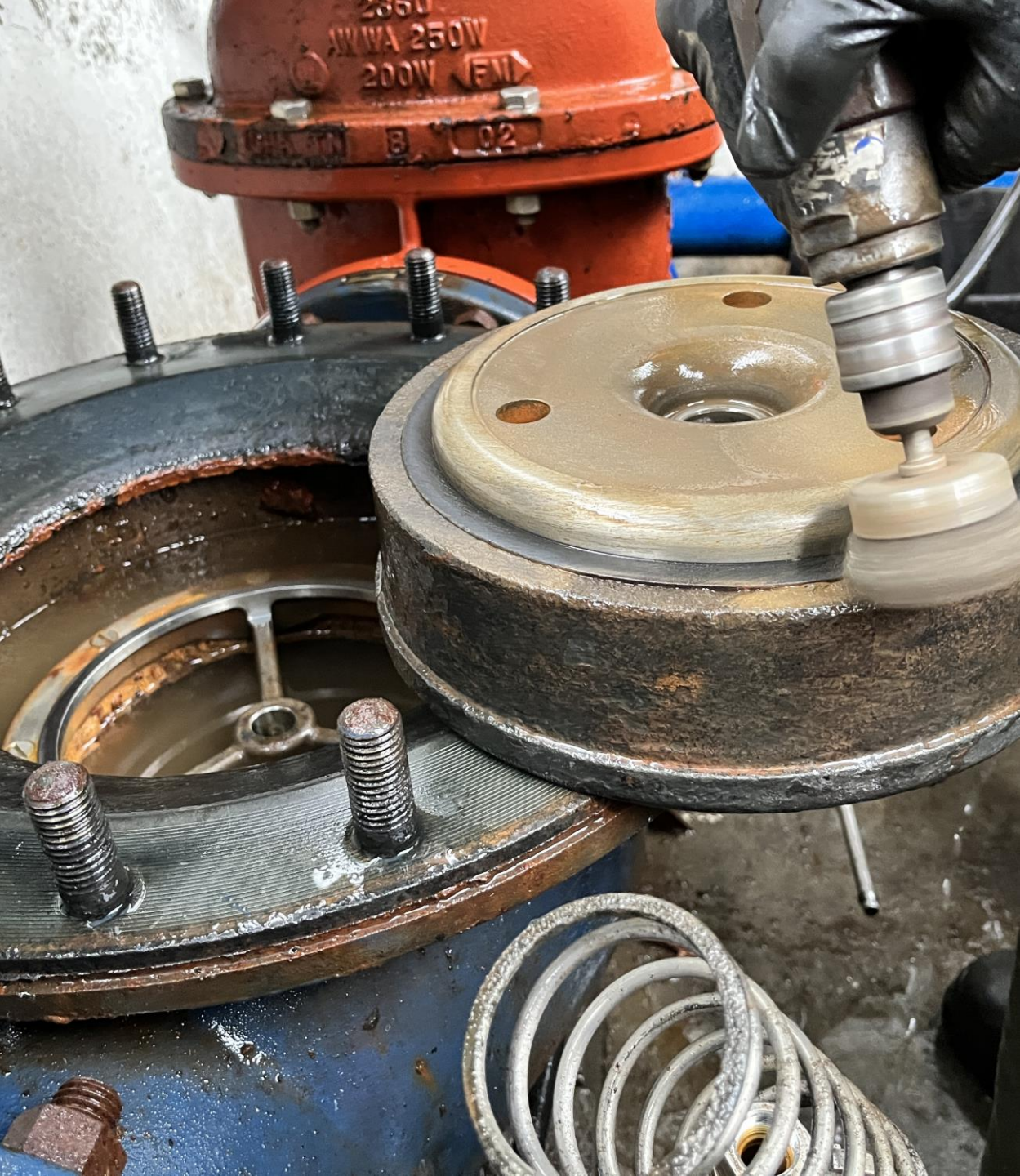

Cimco-GC
SYSTEMS

Control Valve Main Body Maintenance

Why Control Valves Don't Work: Common Causes

- Misapplication?
- Power and/or sensing lines external of the valve not connected
- No preventative maintenance performed in years?
- User Error...



Preventative Maintenance

- Reduces Operating Costs
 - Valves that can't go full open cause more friction loss
 - Valves that can't go closed may over pressurize line

Preventative Maintenance

- Reduces Operating Costs
 - Valves that can't go full open cause more friction loss
 - Valves that can't go closed may over pressurize line
- Reduces Emergencies
 - Proactive Maintenance reduces the chance of emergencies

Preventative Maintenance

- Reduces Operating Costs
 - Valves that can't go full open cause more friction loss
 - Valves that can't go closed may over pressurize line
- Reduces Emergencies
 - Proactive Maintenance reduces the chance of emergencies
- Reduces Valve Replacement costs
 - Cheaper to fix than to replace

Preventative Maintenance

- Do you regularly change the oil in your car?

(or)

- Do you wait until the engine fails before changing the oil?

Typical Preventative Maintenance Program:

- Make a Complete Valve List
 - Include Site Location
- Obtain IOM Manuals
- Schedule Maintenance
 - 5 Year Rebuilds
 - Yearly Inspections
- Frequency depends on conditions such as:
 - Fluid Corrosiveness, Differential, Velocity
- Keep accurate service records

CLA-VAL
AUTOMATIC CONTROL VALVES

90-01/690-01

Place this manual with personnel responsible
for maintenance of this valve

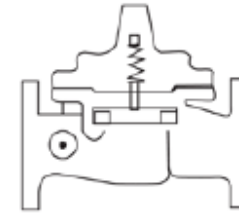

INSTALLATION

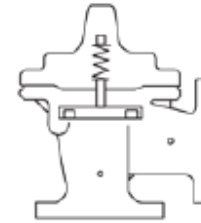

OPERATION

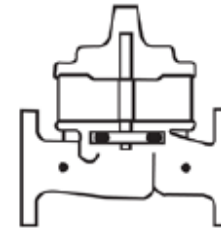

MAINTENANCE



CLA-VAL - P.O. BOX 1925 - NEWPORT, CA 92659-0325 - (415) 732-4866 - FAX: (415) 548-5441
CLA-VAL CANADA LTD. - 4667 Christie Drive - Beamsville, Ontario, L0R 1B4 Canada - (905) 563-4963

Preventative Maintenance

- A simple to use tool to manage the service scheduling of your automatic control valves.
- Works on Desktop and Mobile App
- Secure

 **Link2Valves™**
Simplified Control Valve Service Management



Where to find the IOM Manual

Go to Cla-Val.com and click “Waterworks” section.

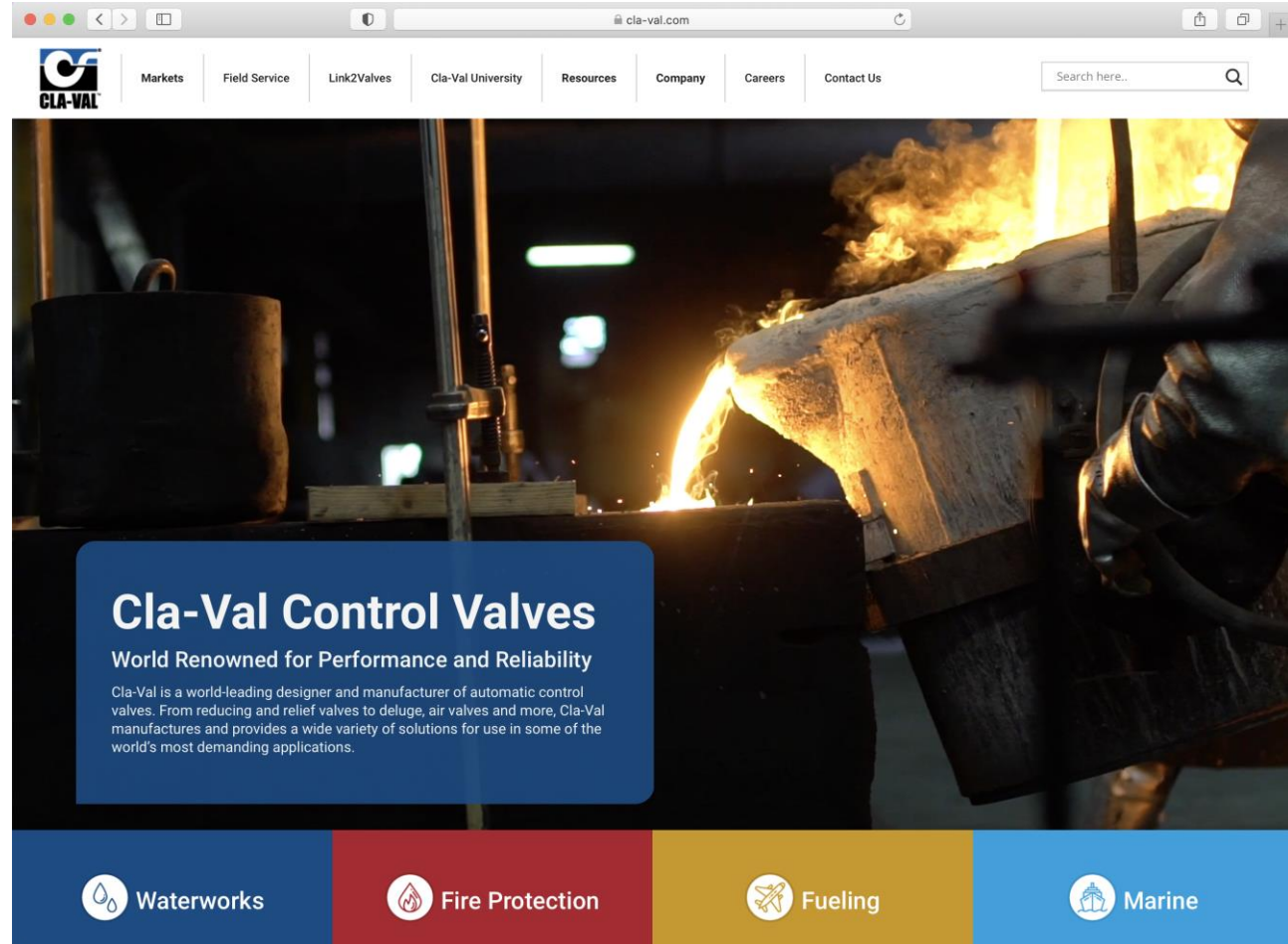

Where to find the IOM Manual

Select "Data Sheets/Manuals" from "Resources" drop-down.

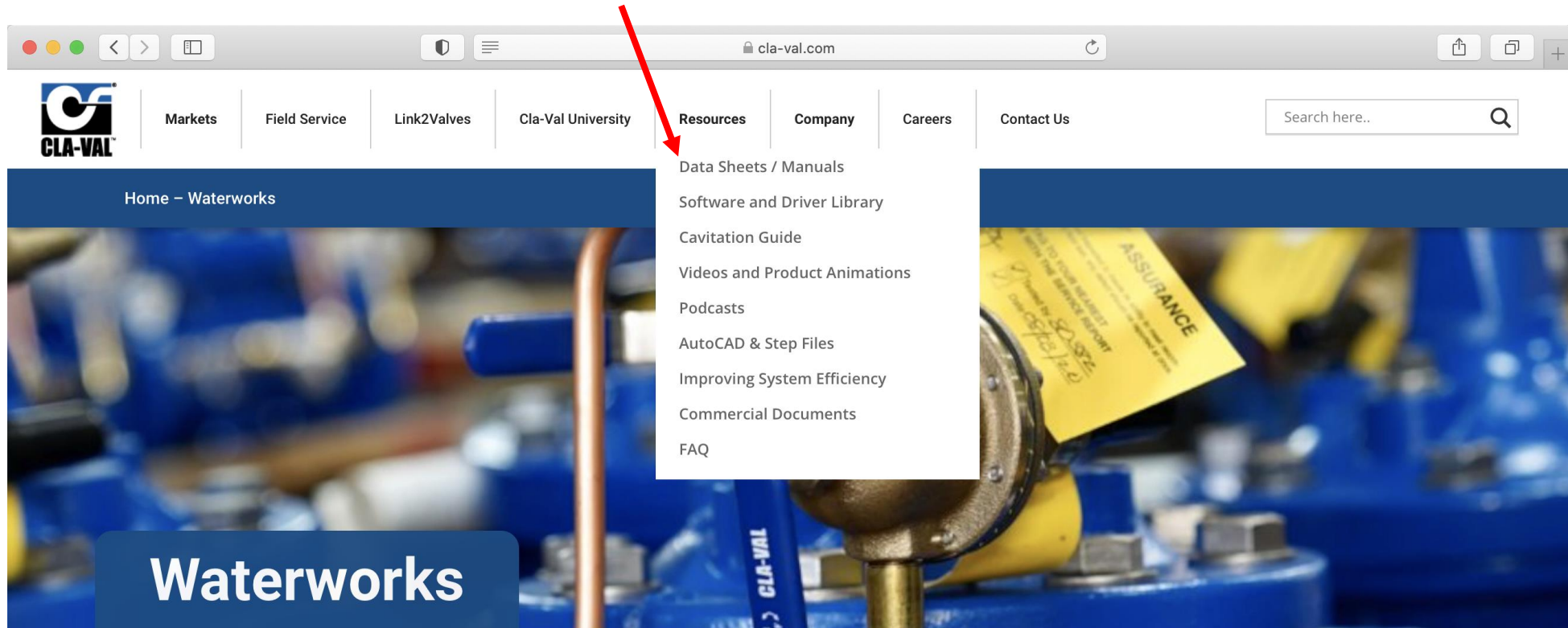

Cla-Val automatic control valve products perform with precision and accuracy to provide exact pressure, flow, level, surge and pump control.

As pioneers in water supply and distribution systems, our proven automatic control valves are specifically designed to meet the requirements of today's municipal water utility systems.

Where to find the IOM Manual

Data Sheets & Manuals

Waterworks Datasheets / Manuals

33A	35WW	124-01 & 624-01	210-01KO	210-17 & 610-17
33AWS	36 Series	124-02 & 624-02	210-02 & 610-02	210-27 & 610-27
34 Series	36WW	124-14 & 624-14	210-03 & 610-03	211-16
34WW	38 VB/AR Series	129-01 & 629-01	210-09 & 610-09	427-01 & 627-01
35 Series	39 Series	210-01 & 610-01	210-16 & 610-16	428-01 & 628-01
CDS6-A	501A Series	584 Series	81-02 & 681-02	133-AW
CDS7	580 Series	585 Series	81-12	136-01 & 636-01
CDS7-DO	581 Series	586 Series	81-18	40-01 & 640-01
CF1-C1	582 Series	587 Series	133-01 & 633-01	40-25 & 640-25
CFC2	583 Series	81-01 & 681-01	133-AV	43-01 & 643-01
49-01 & 649-01	100-01H	100-04	100-23	100-44
61-02KO	100-01KO	100-20	100-30	100-46
61-47	100-02	100-20KO	100-31	7100
X52E	100-02KO	100-21	100-43	CDHS-34
100-01	100-03	100-22	SC-22D	CRL-34
UP-22D	CSM-11	X101	X117C	X43H
VC-22D	CV	X101AR	X117D	X46A
CRA	Dura-Kleen Stem	X101C	X140-1	131-01 & 631-01
CRD	F76	X102	X141	131-22 & 631-22
CRD-1	VHB	X105L & X105L2	X141-PT	131-66 & 631-66
131-73 & 631-73	CTC-33	90-05 & 690-05	92-07 & 692-07	95-01 & 695-01
390-02 & 3690-02	590-01 & 6590-01	90-37 & 690-37	93-01 & 693-01	CRD-L
390-07 & 3690-07	790-01	90-48 & 690-48	94-01 & 694-01	250-01 & 605-01
98-06 & 698-06	90-01 & 690-01	90-99	94-22 & 694-22	50-01 & 650-01
CRD-34	90 & 690-01KO	92-01 & 692-01	94-58 & 694-58	50-01KO
50-05 & 650-05	550-01 & 6550-01	CRL & 55F	60-73 & 660-73	RF-DBF-SB
50-33 & 650-33	552-01 & 6552-01	CRL-60	60-BY & 660-BY	RF-DBI
50-90 & 650-90	55B-60	60-11 & 660-11	61-02 & 661-02	RF-DBI-IN
52-01 & 652-01	58-01 & 658-01	60-19 & 660-19	PC-22D	RF-DBI-LH
52-03 & 652-03	750-01	60-32 & 660-32	RF-DBF	RF-DBJ
RF-DBO				
RF-DBO-SB				
136-03 & 636-03				

Select the particular valve.

Where to find the IOM Manual

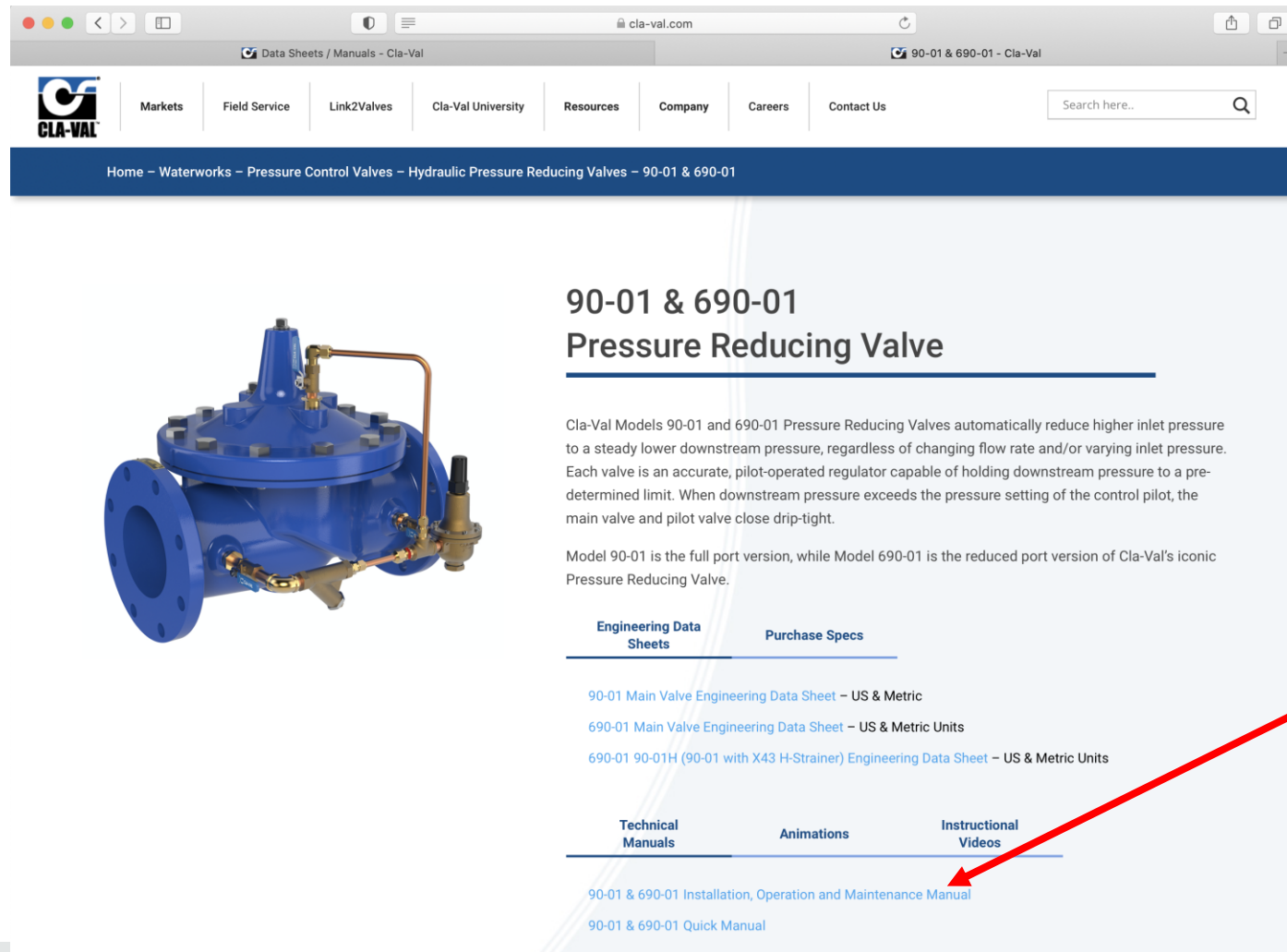

cla-val.com

Data Sheets / Manuals - Cla-Val

90-01 & 690-01 - Cla-Val

Markets | Field Service | Link2Valves | Cla-Val University | Resources | Company | Careers | Contact Us

Search here..

Home – Waterworks – Pressure Control Valves – Hydraulic Pressure Reducing Valves – 90-01 & 690-01

90-01 & 690-01 Pressure Reducing Valve

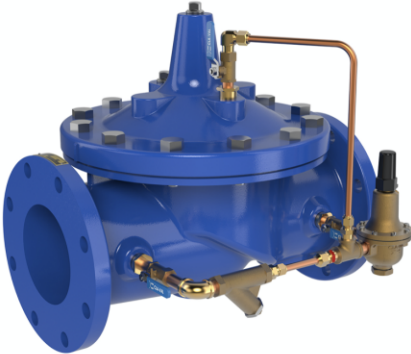

Cla-Val Models 90-01 and 690-01 Pressure Reducing Valves automatically reduce higher inlet pressure to a steady lower downstream pressure, regardless of changing flow rate and/or varying inlet pressure. Each valve is an accurate, pilot-operated regulator capable of holding downstream pressure to a pre-determined limit. When downstream pressure exceeds the pressure setting of the control pilot, the main valve and pilot valve close drip-tight.

Model 90-01 is the full port version, while Model 690-01 is the reduced port version of Cla-Val's iconic Pressure Reducing Valve.

Engineering Data Sheets | **Purchase Specs**

[90-01 Main Valve Engineering Data Sheet – US & Metric](#)

[690-01 Main Valve Engineering Data Sheet – US & Metric Units](#)

[690-01 90-01H \(90-01 with X43 H-Strainer\) Engineering Data Sheet – US & Metric Units](#)

Technical Manuals | **Animations** | **Instructional Videos**

[90-01 & 690-01 Installation, Operation and Maintenance Manual](#)

[90-01 & 690-01 Quick Manual](#)

Click the Installation, Operation, and Maintenance Manual

Work Safely

- Be aware of traffic
 - Keep defensible space
 - Light boards, cones, etc.
- Vaults/Confined Space
 - Pump to remove water, gas detectors, harness, crane to help cover removal
- Work as a team
 - One works on main valve, other works on pilots



Hytrol Service Tips

1. Index the Cover to the Body to ensure proper alignment of tubing (a Sharpie works).
2. Pull STRAIGHT UP on cover and diaphragm assembly to avoid damage to seat and stem.
3. Record service activity on Preventive Maintenance form

 Cla-Val Automatic Control Maintenance Record

Form to be completed at the jobsite

Date:	Time Arrived:	Time Departed:
Cla-Val Technician:	Customer Contact:	
Customer Co. Name:	Location/Site Name:	

Equipment Serviced

Valve Model:	Serial #:	Service/Repair Performed:

Follow-Up Requirements

Valve Model:	Serial #:	Required action:

Preventative Recommendations

Valve Model:	Serial #:	Date for return service:

Customer signature _____ Date _____

Cla-Val • 800.942.6326 • www.cla-val.com

Excessive Build Up



Hytrol Service: Clean Internal Parts

- Clean inside the cover
- Clean the seat
- Clean the body ports
- Pilot System
 - Pilots, Strainers, Speed Controls, etc.



Clean Exposed Threads Thoroughly



Start to Finish

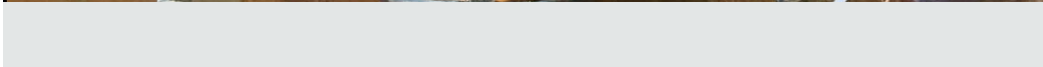

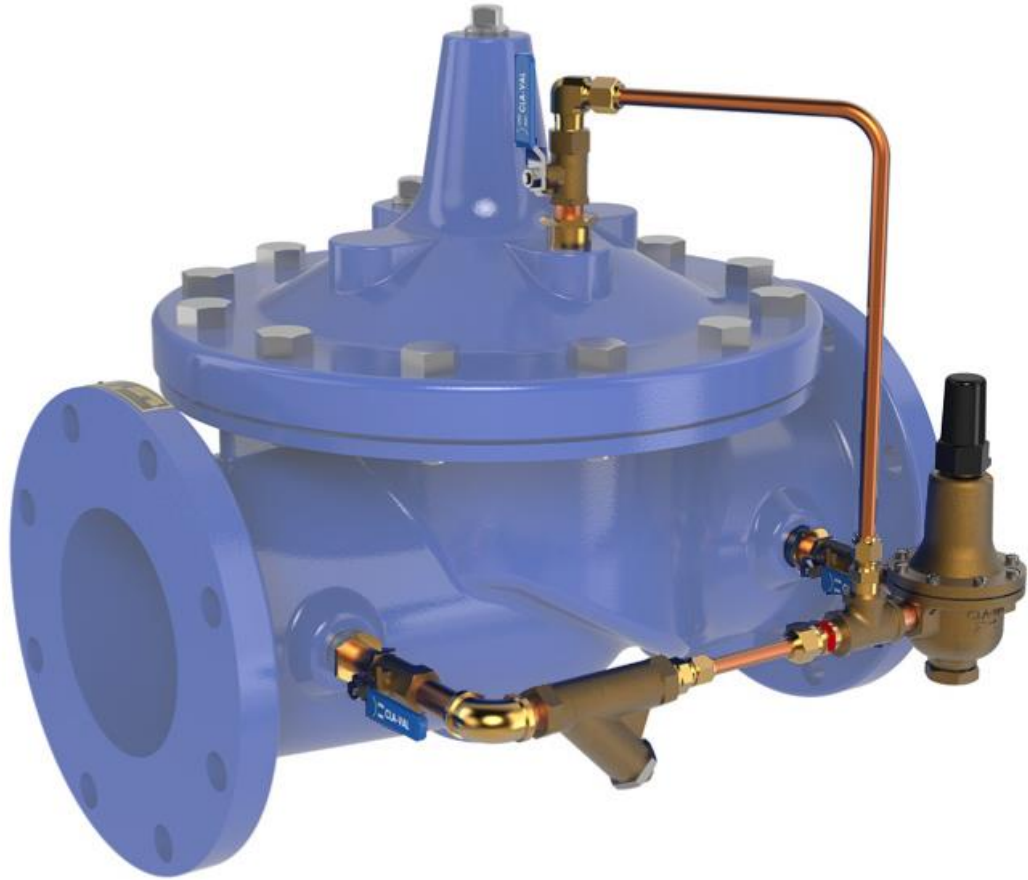

Pilot Systems Review

Pilot Systems Provide Functionality for a Valve

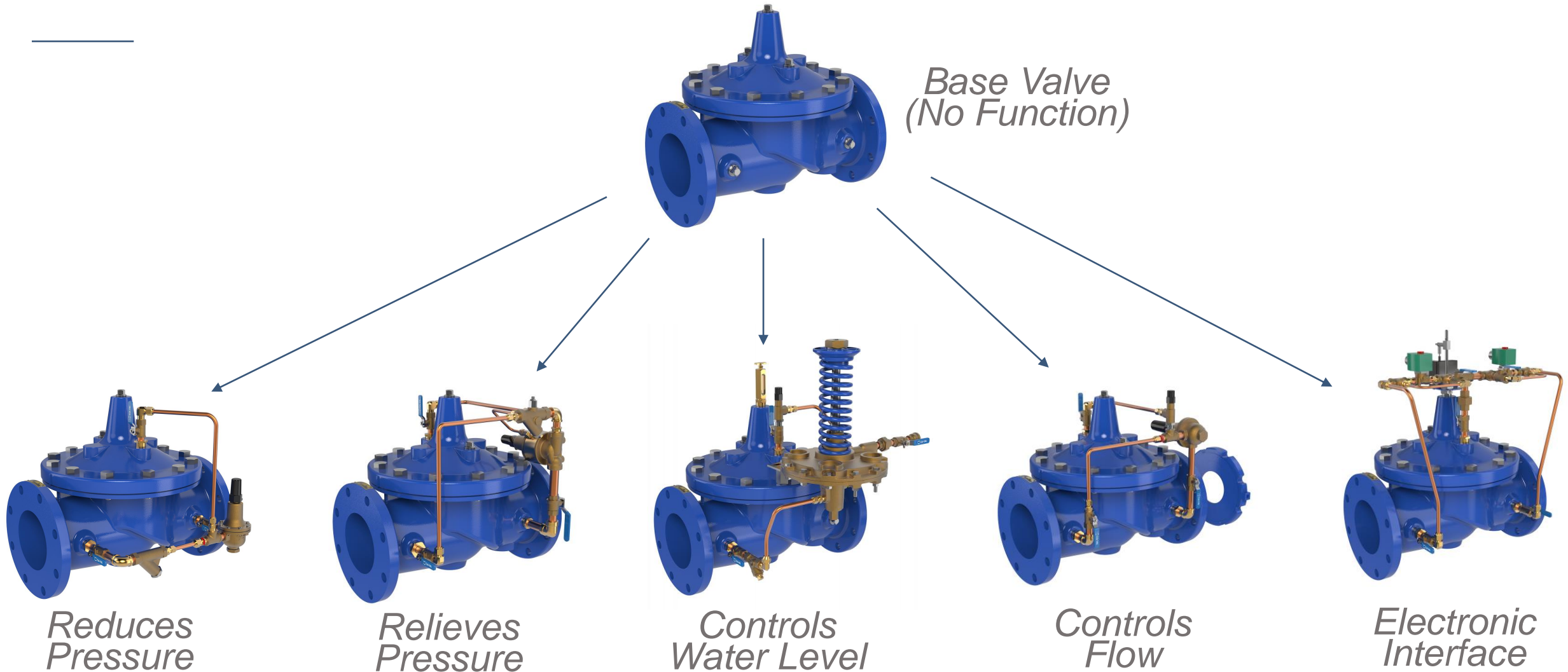

Pilot Controls

Move water on and off the cover of the valve

Common Features

- Mechanical pilots
 - CRD, CRL, CRA, CDS6A, etc.
- Solenoid controls
- Tubing and fittings
 - Copper tubing and brass fittings standard
 - *We highly recommend Stainless Steel tubing and fittings due to new low-lead copper and brass*
- Strainers, speed controls, sensors, check valves, ball valves, auxiliary Hytrols, etc.

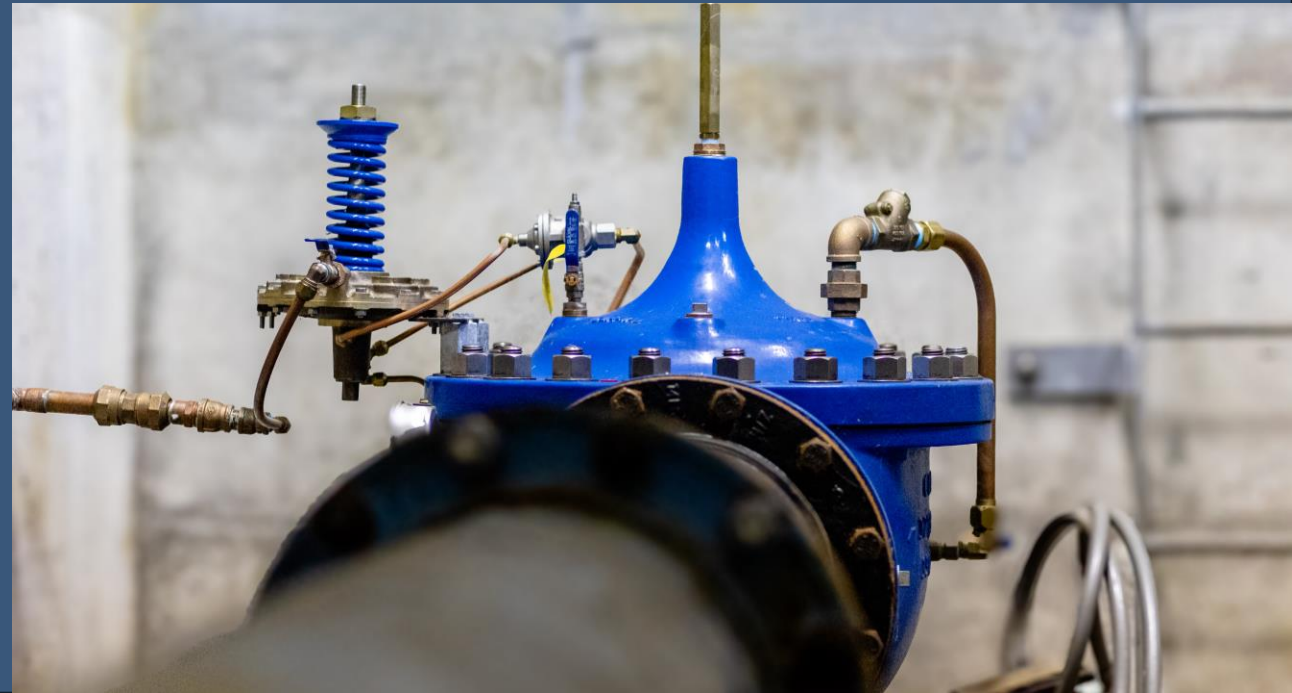

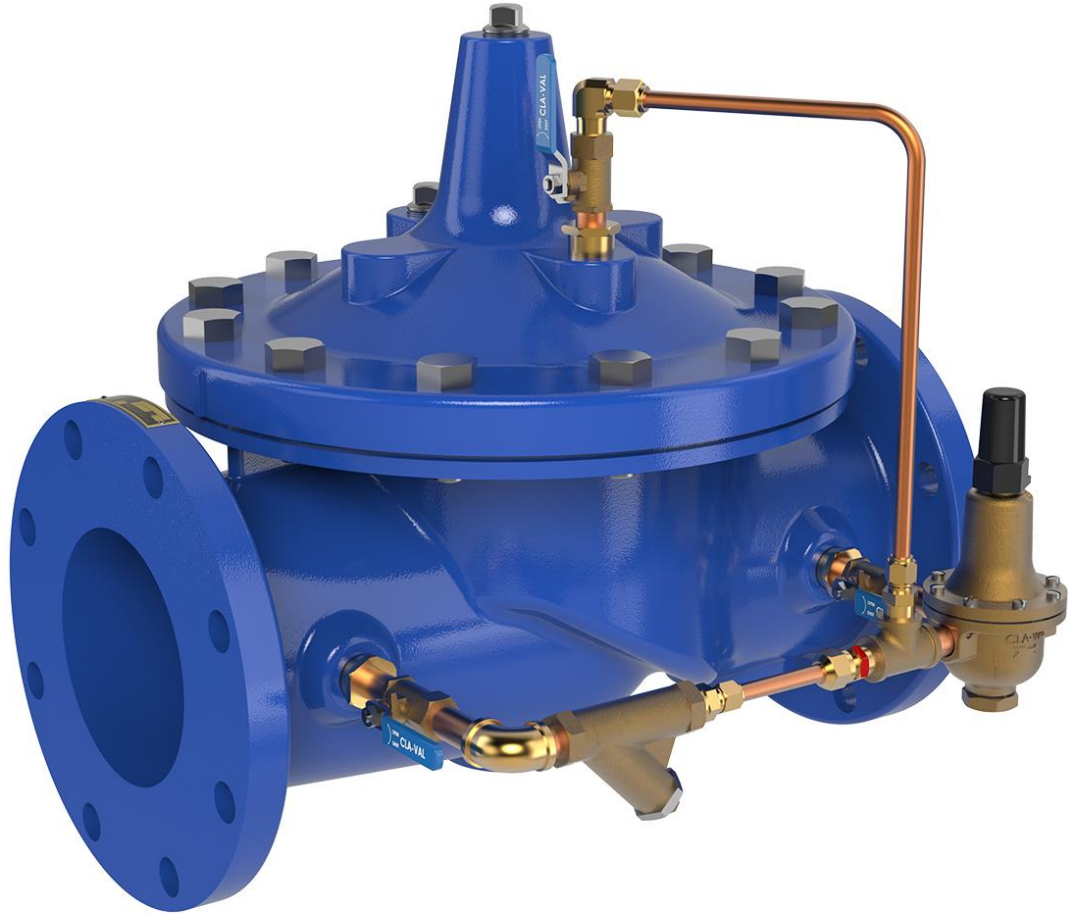

Pressure Reducing Valves

Pressure Reducing Valves

Maintain a constant downstream pressure regardless of inlet pressure or changes in flow rate

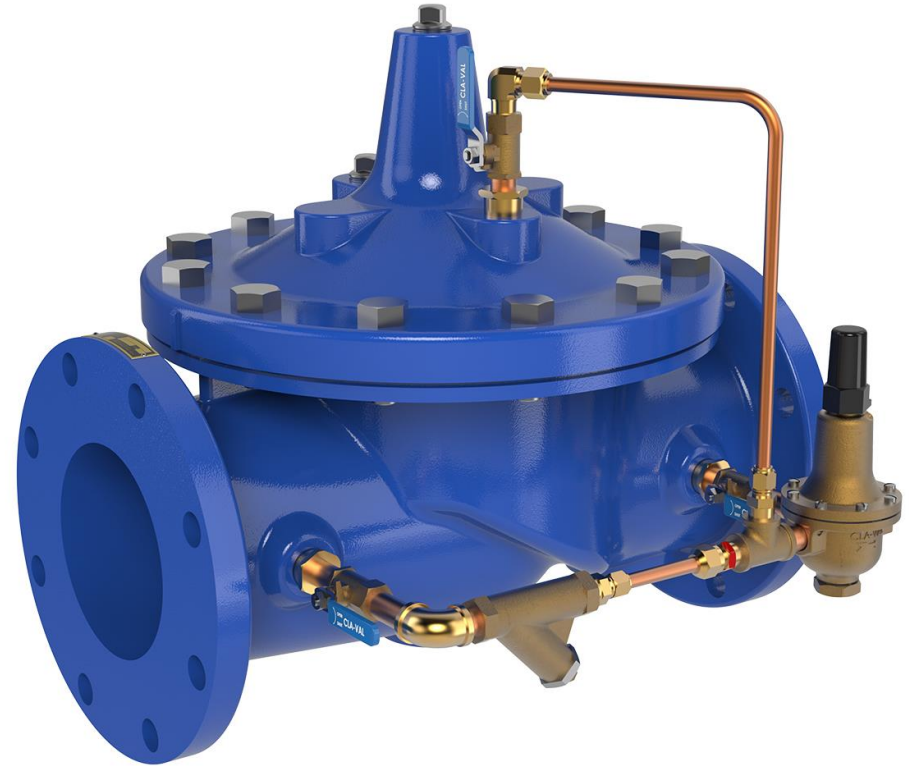

90-01 Components

- Always Included:
 - 100-01 Hytrol Main Valve
 - X58C Restriction Fitting
 - CRD Pressure Reducing Pilot
 - Either an X46A Flow Clean or a X43 “Y” Strainer
- May also Include:
 - Ball valves, Speed controls, X101 valve position indicator, check feature, etc.

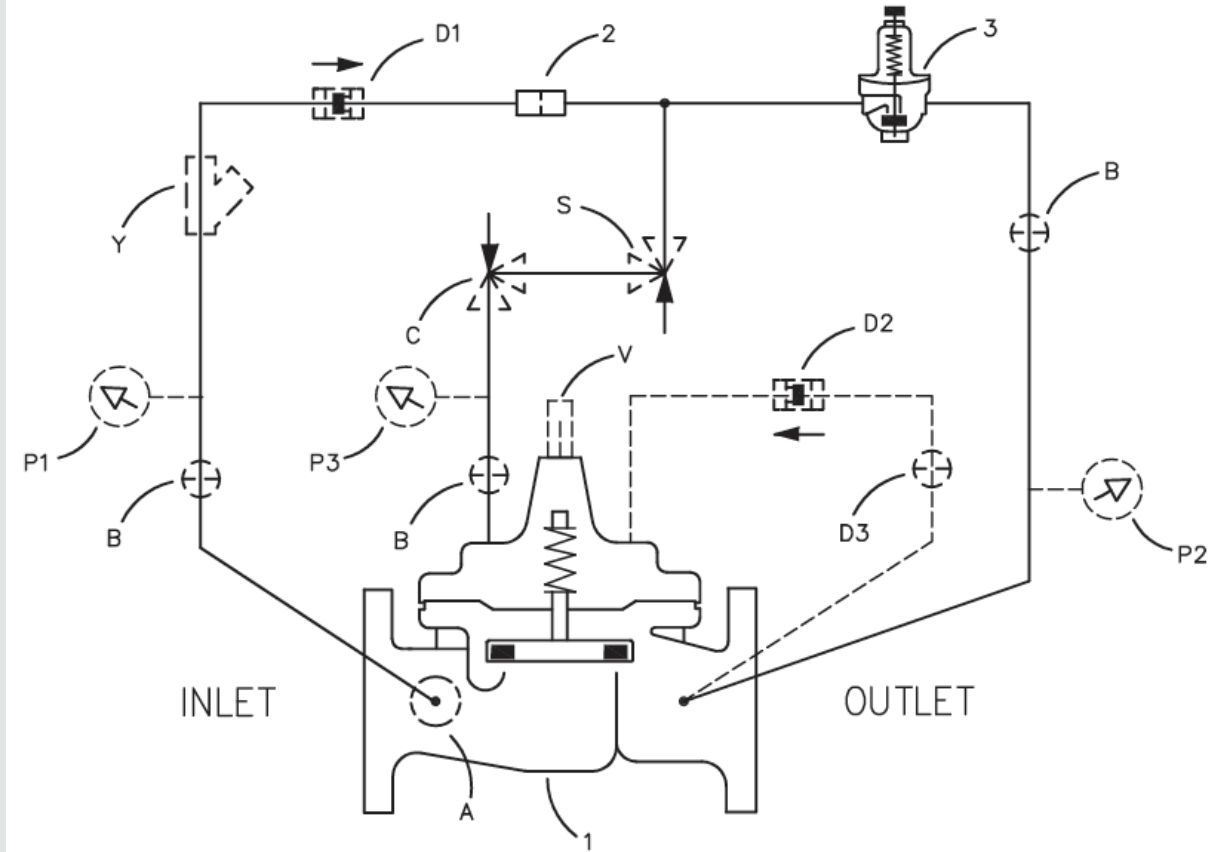

BASIC COMPONENTS

- 1 100-01 Hytrol (Main Valve)
- 2 X58C Restriction Fitting
- 3 CRD Pressure Reducing Control

OPTIONAL FEATURES

- A X46A Flow Clean Strainer
- B CK2 (Isolation Valve)
- C CV Flow Control (Closing)
- D Check Valves with (Isolation valve)
- P X141 Pressure Gauge
- S CV Flow Control (Opening)
- V X101 Valve Position Indicator
- Y X43 “Y” Strainer

CRD Pressure Reducing Pilot Control

C = Control

R D = Reduce



CRD



Hands-on with Pressure Reducing Pilots

Servicing the CRD

CRD Parts List:

ITEM #	DESCRIPTION	PART NO.
1	CAP PLASTIC	67628J
2	ADJUSTING SCREW	7188201D
3	JAM NUT 3/8-16	6780106J
4	COVER	C2544K
5	SCREW	6795312F
6	SPRING GUIDE	71881H
	SPRING	
7	PSI RANGE - 1-7	82575C
	PSI RANGE - 2-30	81594E
	PSI RANGE - 15-75	71884B
	PSI RANGE - 30-300	71885J
8	HEX NUT 303 SS	71883D
9	BELLEVILLE WASHER	7055007E
10	DIAPHRAGM WASHER	71891G
11	DIAPHRAGM	C6936D
12	YOKE	37137H
13	BODY & SEAT ASSEMBLY	8339702G
13 (A)	BODY	8339301H
13 (B)	SEAT	8339601A
	DISC RETAINER ASSEMBLY	
14	PSI RANGE - 1-7, 2-30	C8348K
	PSI RANGE - 15-75, 30-300	37133G
15	GASKET RED FIBER	40174F
16	PLUG, BODY BRASS	V5653A
17	PLUG, 3/8" NPT	6766003F

Repair Kits

Pilot Control	Kit Stock No.
CRD (w/bucking spring) 1-7psi, 2-30psi	9170002B
CRD (no bucking spring) 15-75psi, 20-105psi, 30-300psi	9170003K



Loosen Set Screw



Remove Cover Screws



Remove Spring



Remove Disc Retainer



Remove Disc



Disc Showing Wear



Disc Showing Wear



Diaphragm & Yoke Assembly



CRD Diaphragm Assembly



Yoke



Diaphragm



Diaphragm Washer



Belleville Washer



Jam Nut



Diaphragm & Yoke Alignment

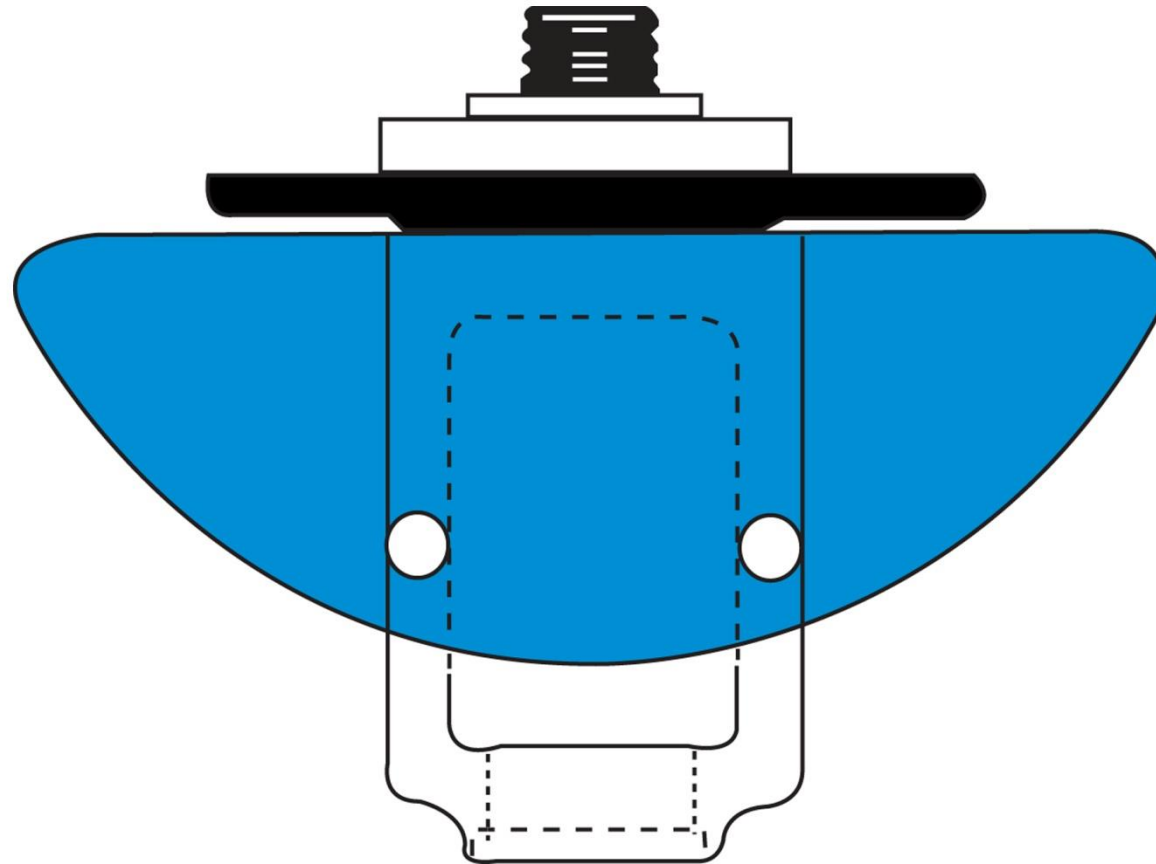

Proper Alignment of Diaphragm to Yoke Assembly



X58 Restrictors

- Small orifice stained **BLUE** – 3/32"
- Large orifice stained **RED** – 1/8"



Common Pilot System Accessories

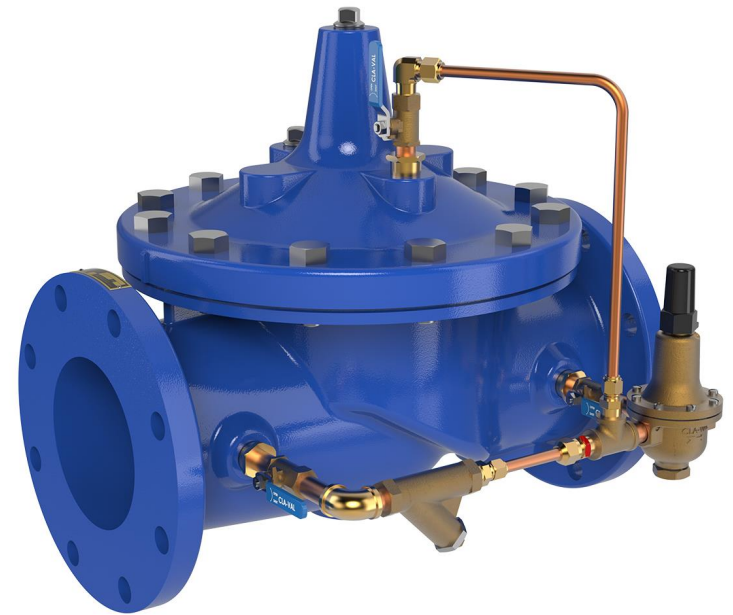
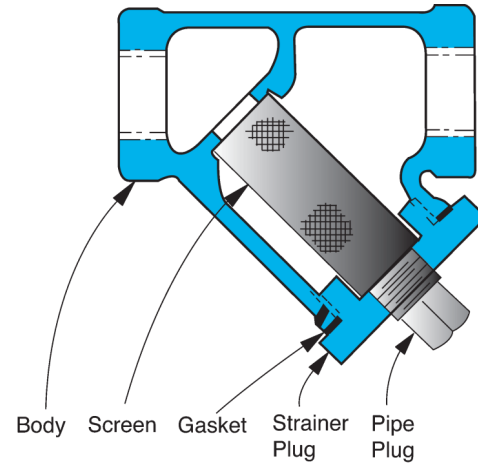

Strainers



X46 Flow Clean Strainer

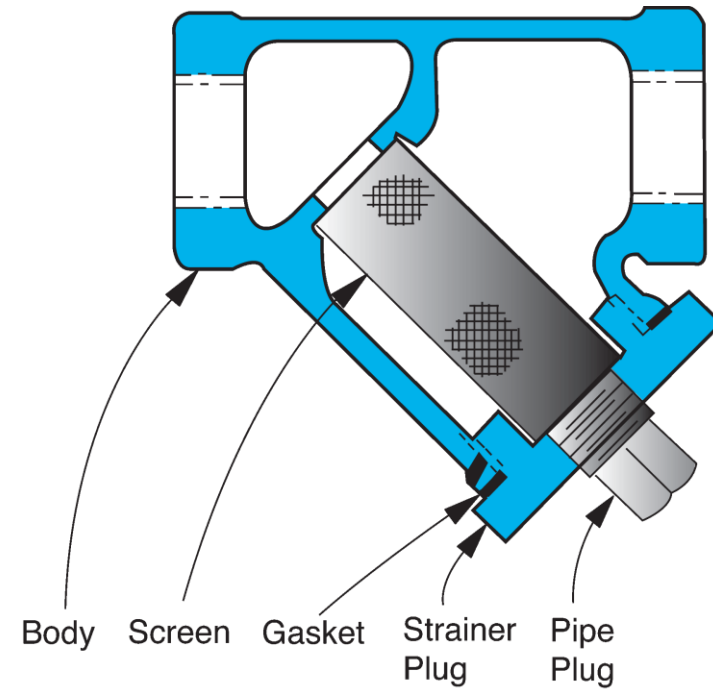

X43 Strainer

Plug into Body

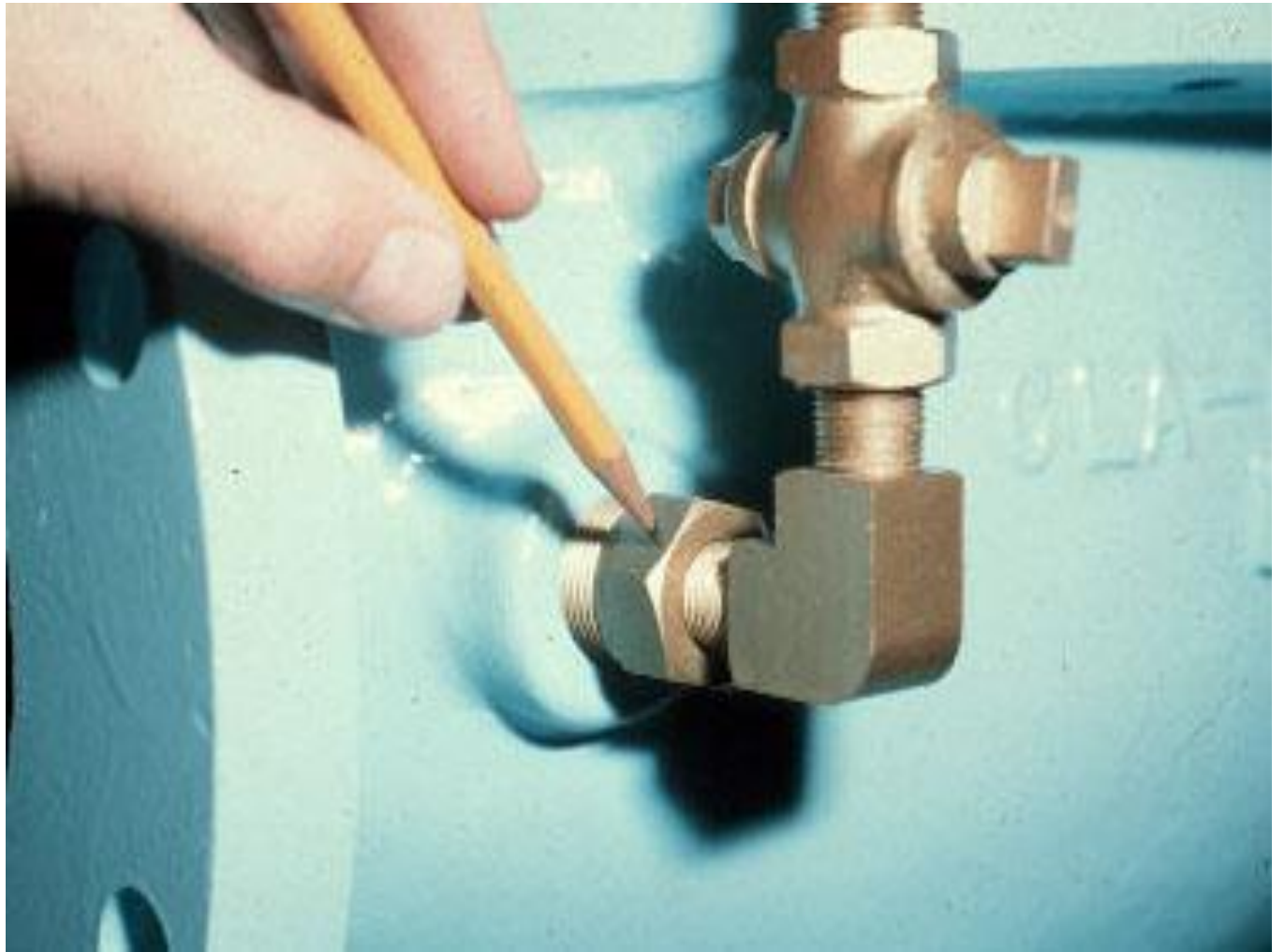

Servicing



High-Capacity Strainers

Optional Automatic Backwashing Assembly

Valve with motor and timer replaces ball valve drain port for automatic backflushing at pre-programmed intervals. Power required 24 VAC, 50/60 Hz, 4 watts, battery backup.



F76 Strainer



Arion Strainer

Opening & Closing Speed Controls

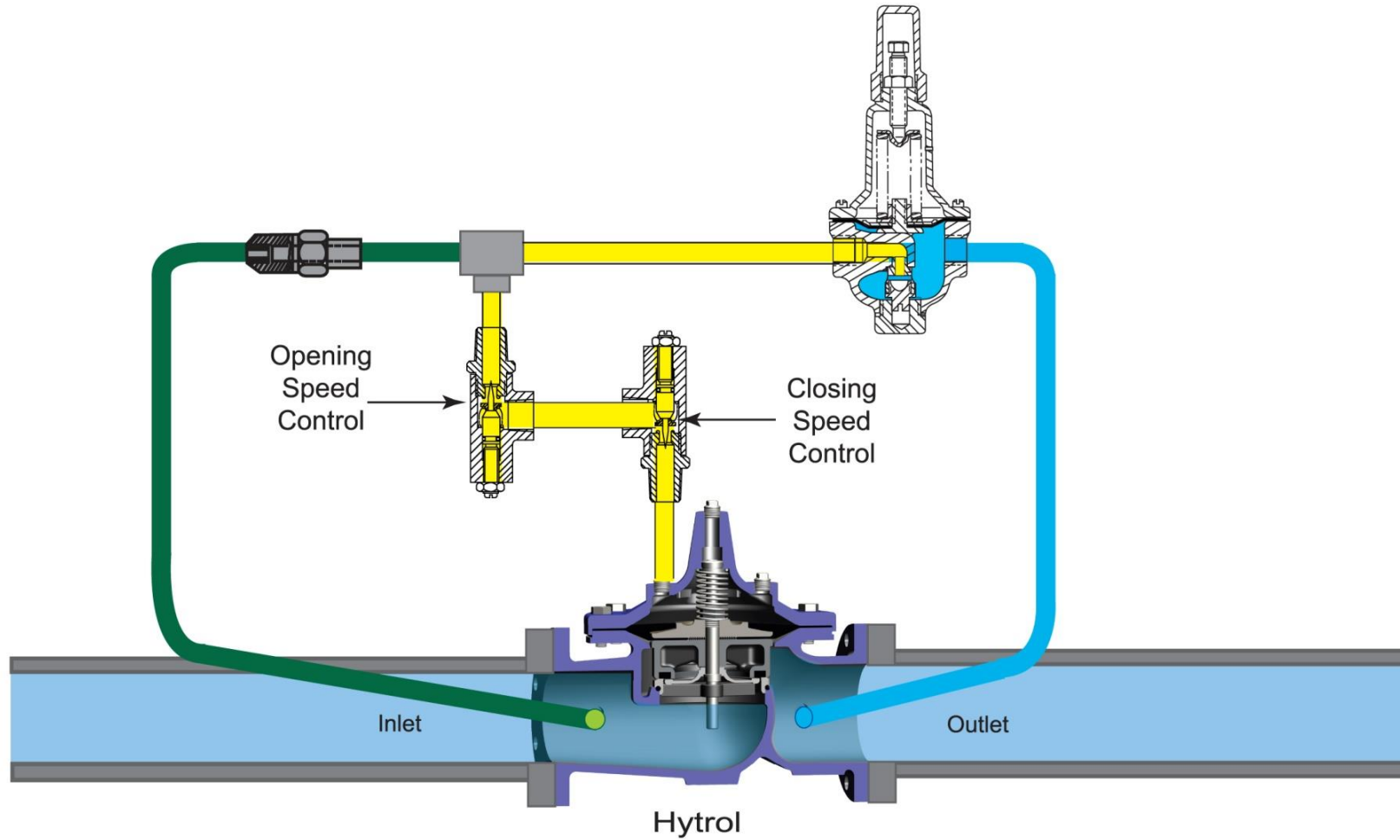

Speed Controls

- Slows down the valve going opened and closed by restricting flow
 - Preventing water hammer
- Opening or Closing (or both)
- PRV Start Point – Screw in all the way, back out 3 turns
- Relief Set Point – Screw in all the way, back out ½” turn
- Servicing – Clean the Disc and Needle



CV Speed Controls

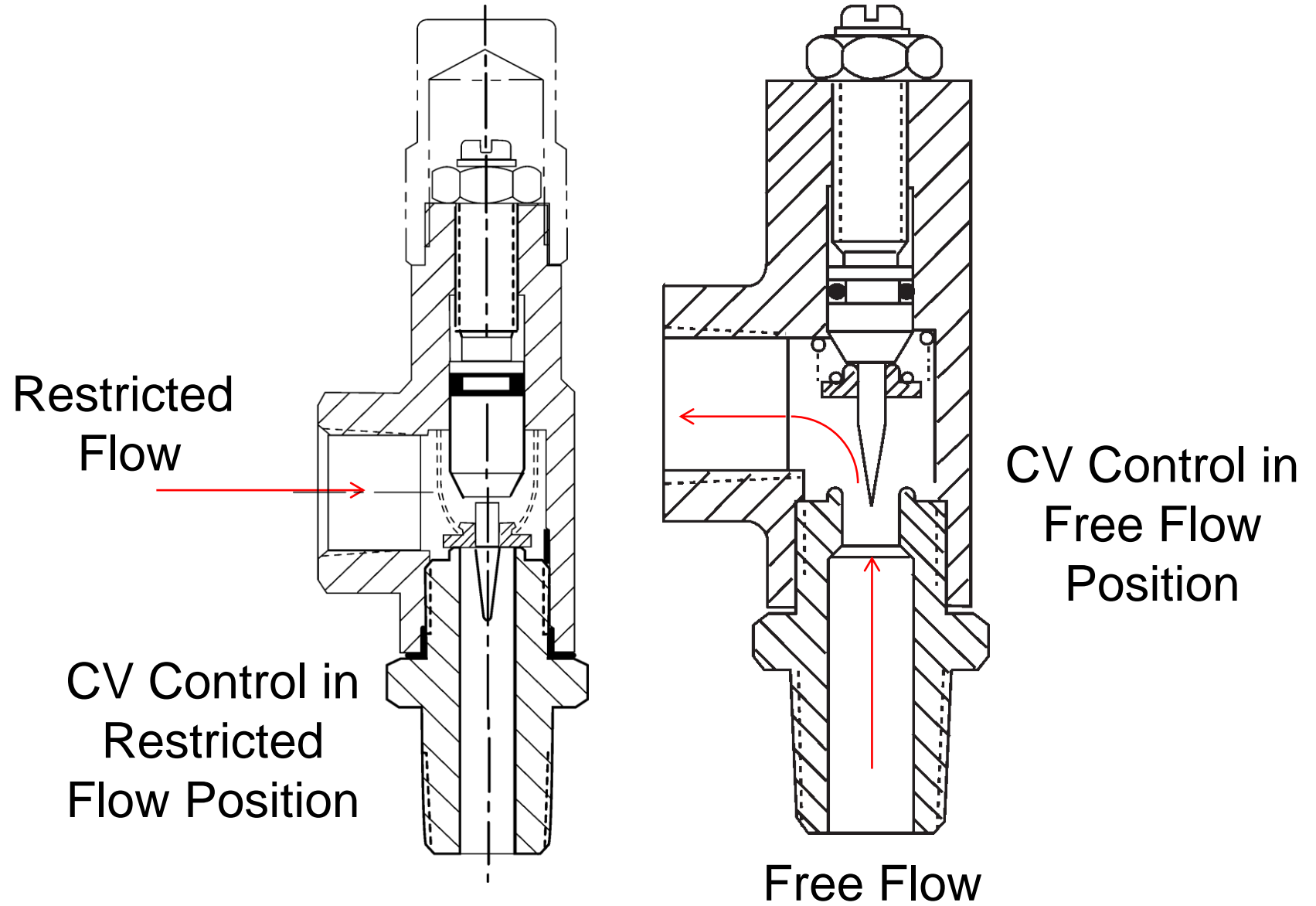



Cimco-GC
SYSTEMS

Questions?



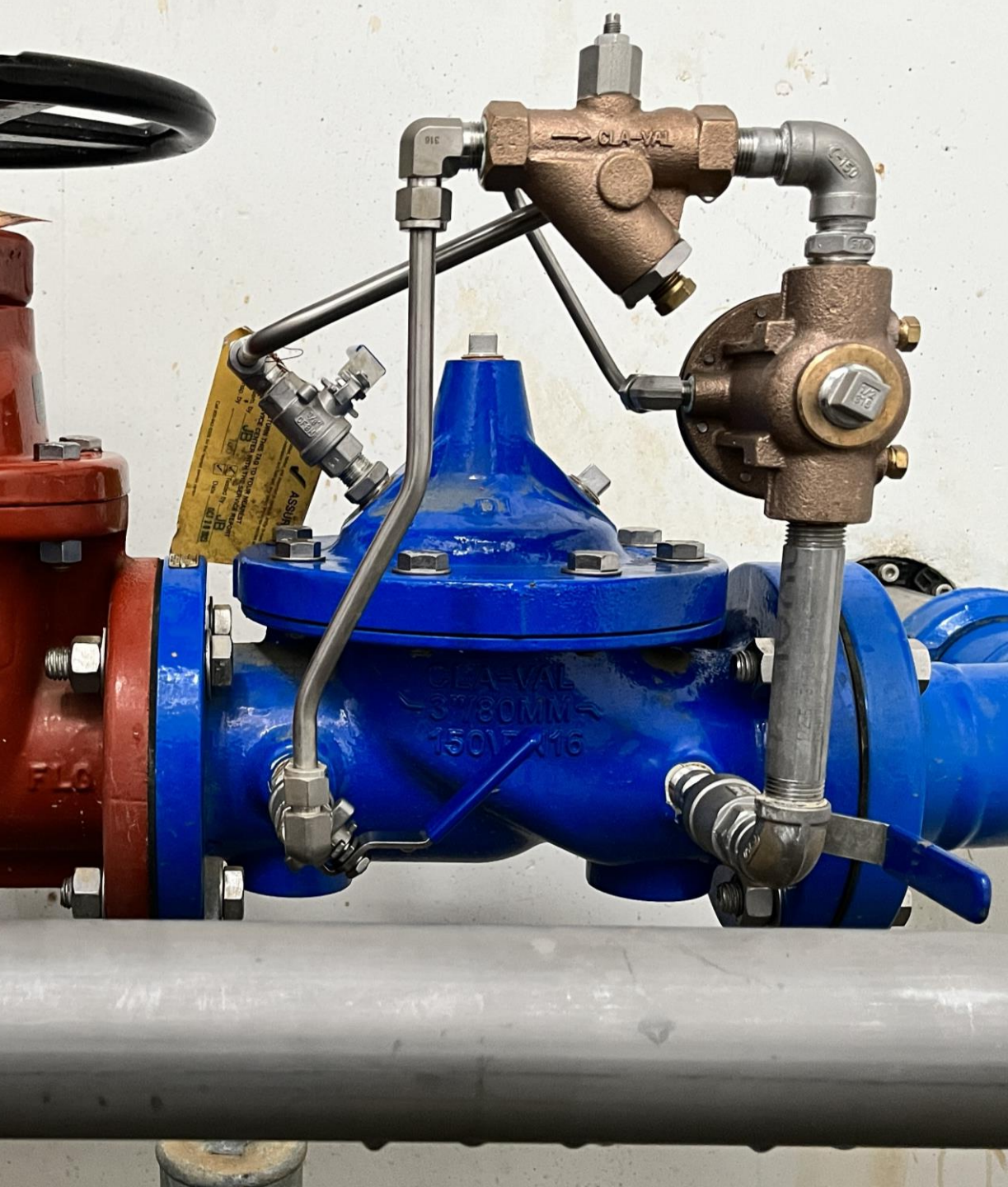

Cimco-GC
SYSTEMS

Pressure Relief Valves

Pressure Relief Valves

Maintain a maximum upstream pressure regardless of outlet pressure or changes in flow rate

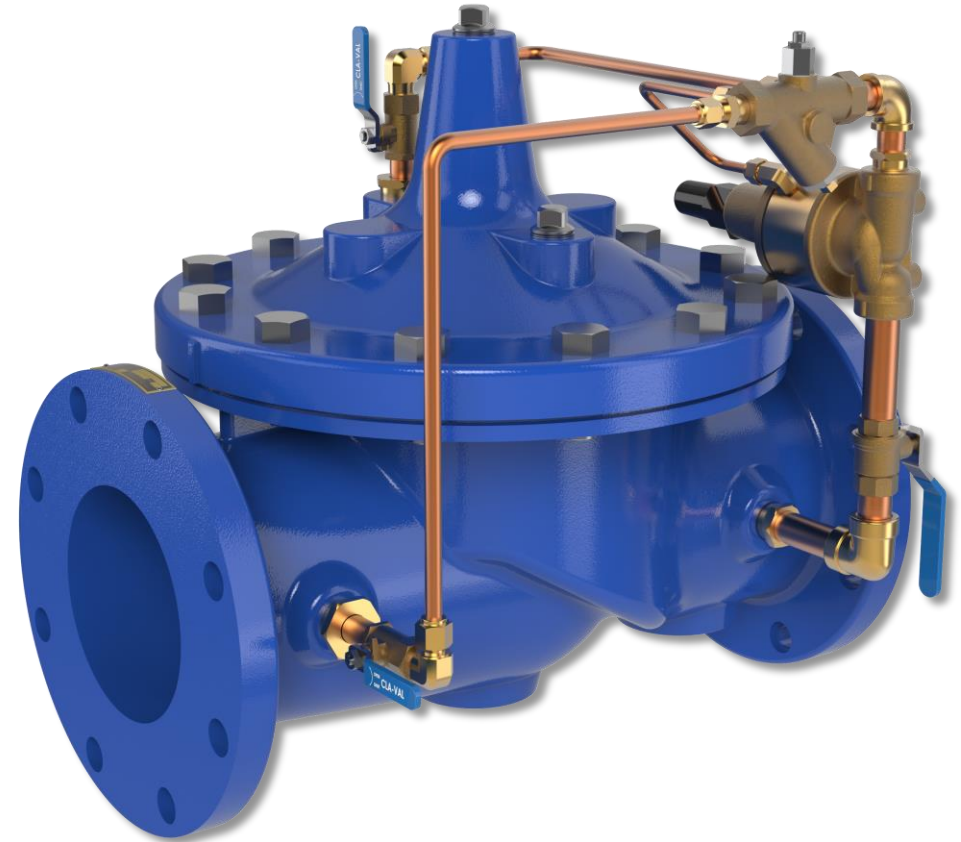

50-01 Components

Most Common Pressure Relief Valve

- Always Included:
 - 100-01 Hytrol Main Valve
 - X42N-2 Strainer Needle Valve
 - CRL Pressure Relief Control
- May also Include:
 - Ball valves, Speed controls, X101 valve position indicator, check feature, etc.

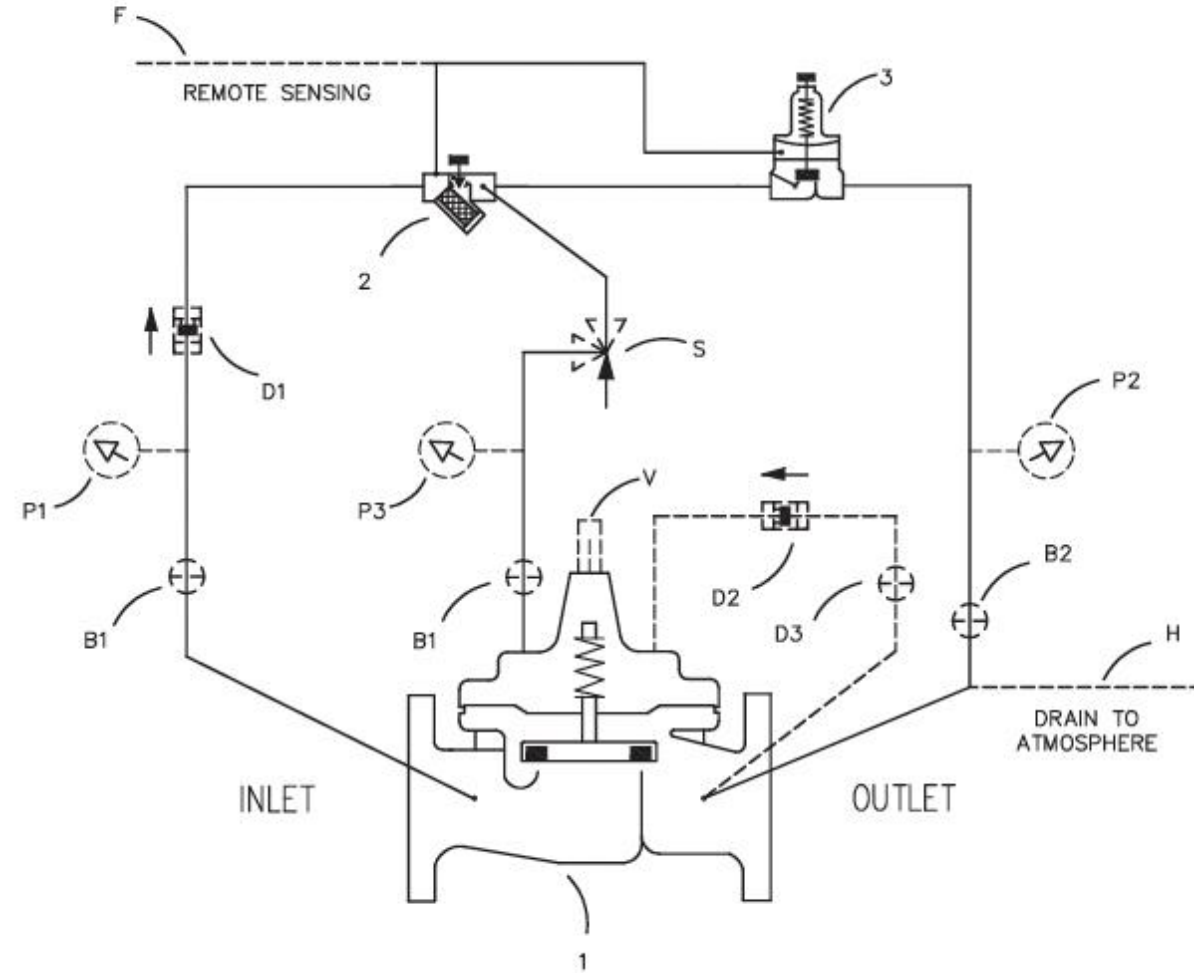

BASIC COMPONENTS

- 1 100-01 Hytrol (Main Valve)
- 2 X42N-2 Strainer Needle Valve
- 3 CRL-60 Pressure Relief Control

OPTIONAL FEATURES

- B CK2 (Isolation Valves)
- D Check Valves with Isolation valve
- F Remote Sensing
- H Drain to Atmosphere
- P X141 Pressure Gauge
- S CV Flow Control (Opening)
- V X101 Valve Position Indicator

X42N-2 Strainer Needle Valve

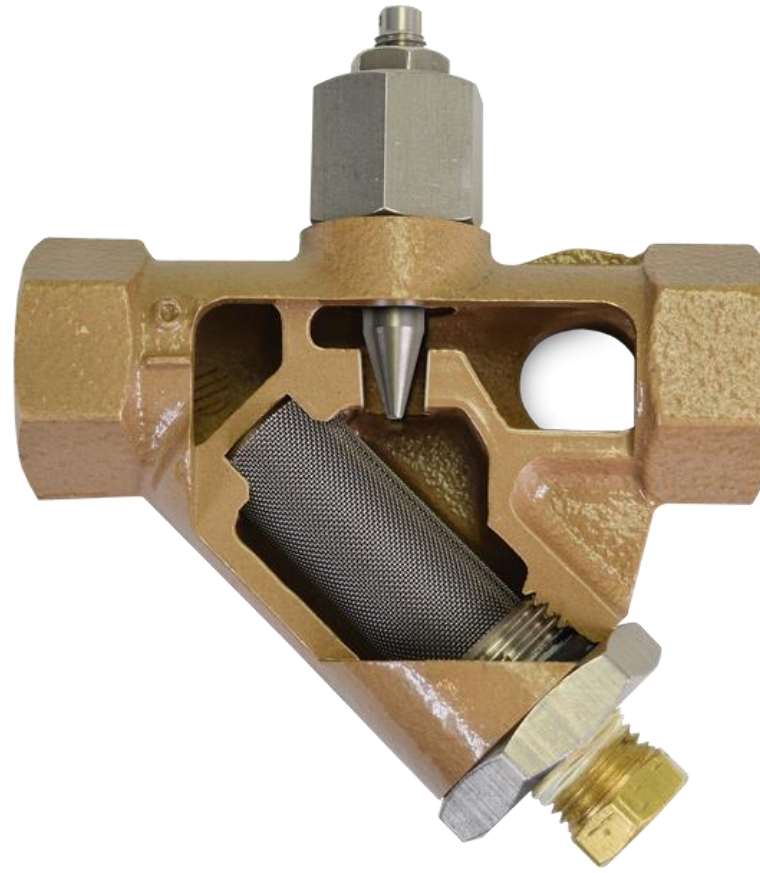

X42N-2 Adjustment

Pressure

Turns out from seat

- Under 80psi
- Over 80psi

1/2

1/4

Does Not Come Preset

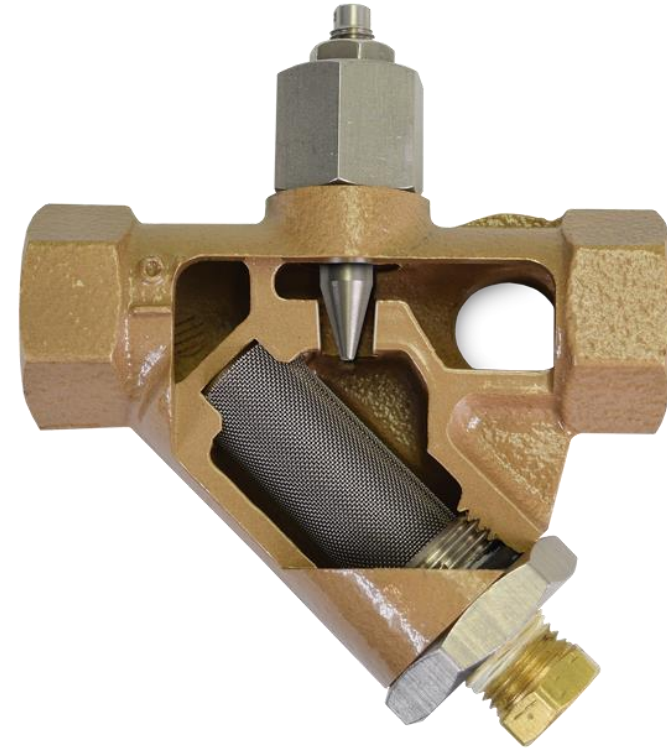

CRL/CRL-60 Pressure Relief Pilot Control

- **C** = Control
- **R L** = Relief



CRL



CRL-
60

CRL Pressure Relief Pilot Control

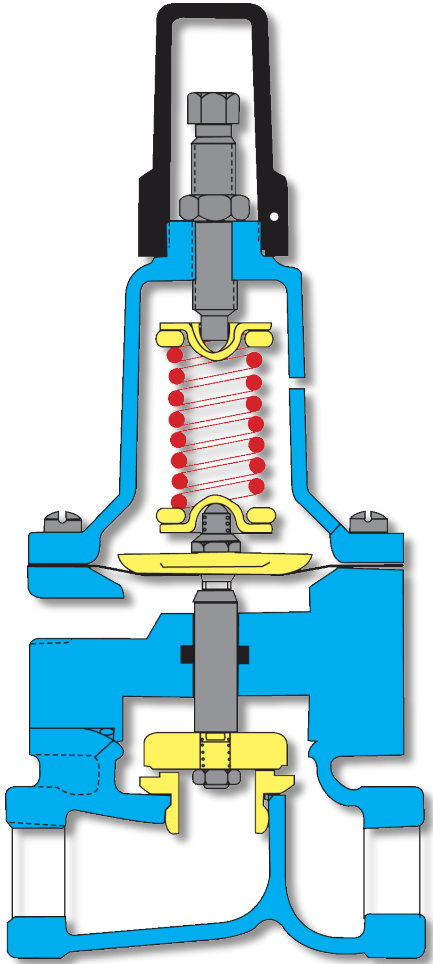

- Normally closed
- Opens on pressure rise
- Senses inlet pressure remotely
- 11/16" Seat

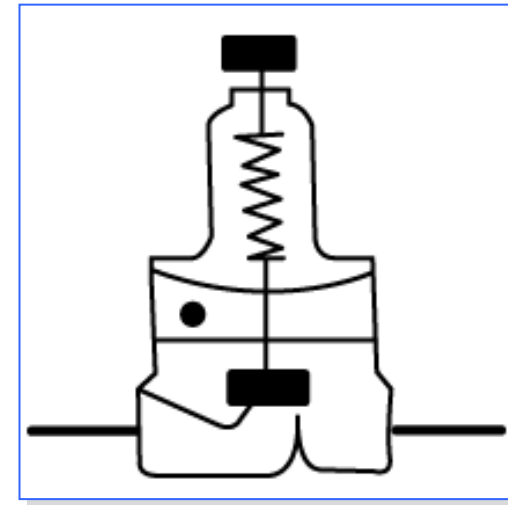

CRL Parts List:

ITEM #	DESCRIPTION	PART NO.
1	CAP PLASTIC	67628J
2	ADJUSTING SCREW	7188201D
3	JAM NUT 3/8-16	6780106J
4	COVER	C2544K
5	SCREW	6795339J
6	SPRING GUIDE	71881H
7	SPRING	
	PSI RANGE - 0-75	71884B
	PSI RANGE - 20-105	20632101E
	PSI RANGE - 20-200	71885J
8	NUT, STEM UPPER	73034B
9	BELLEVILLE WASHER	7055007E
10	DIAPHRAGM WASHER UPPER	71891G
11	DIAPHRAGM	C1505B
12	DIAPHRAGM WASHER LOWER	45871B
13	O-RING, STEM	00746J
14	BODY, POWERUNIT	7920504D
15	O-RING, BODY	00767E
16	O-RING	00902H
17	STEM	8982401F
18	DISC RETAINER	C9158B
19	NUT, HEX, STEM, LOWER	6779806G
20	SEAT	62187A
21	O-RING, SEAT	00718H
22	BODY - 1/2"	C7928K
	BODY - 3/4"	C9083B
23	PLUG, P HXH 1/8	6784701C

FOR 100-300 PSI RANGE - CONSULT FACTORY FOR BOM

Repair Kits

Pilot Control	Kit Stock No.
CRL (55F)	9170007A
UNIVERSAL CRL/CRL-60 Repair Kit - 1/2" & 3/4"	9170041K

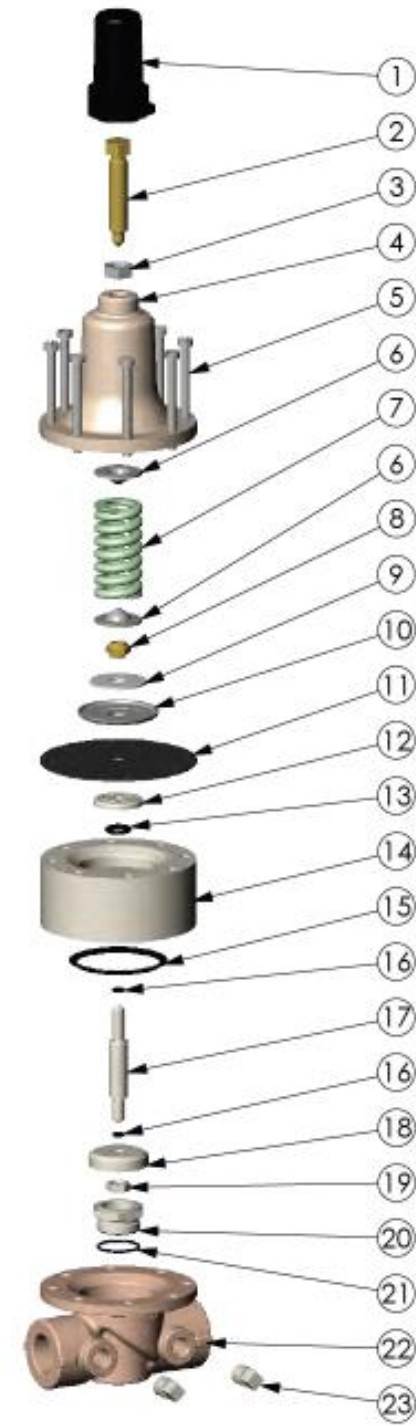

CRL Parts Breakdown

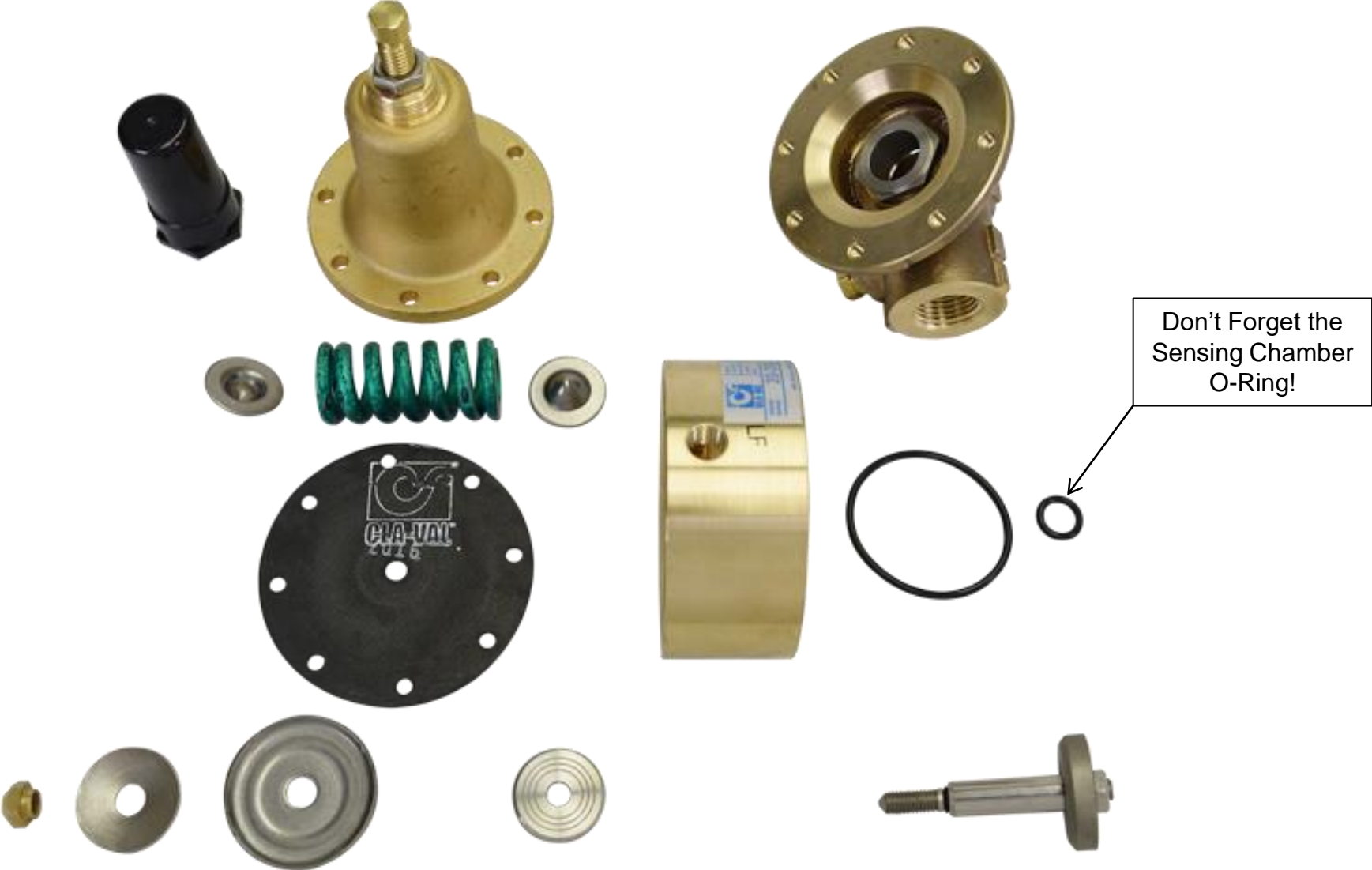

CRL Spring / Guide



CRL Spring Guide



CRL Stem Nut



CRL Belleville Washer



CRL Upper Diaphragm Washer



CRL Diaphragm



CRL Lower Diaphragm Washer



CRL Stem



CRL Disc Retainer / Stem





Cimco-GC
SYSTEMS

2310 Inter Avenue

Questions?

Patrick Miller

Patrick@cimco-gcsystems.com

253-263-3099

[linkedin.com/patrickmiller](https://www.linkedin.com/company/patrickmiller)